

www.pholod.com.ua

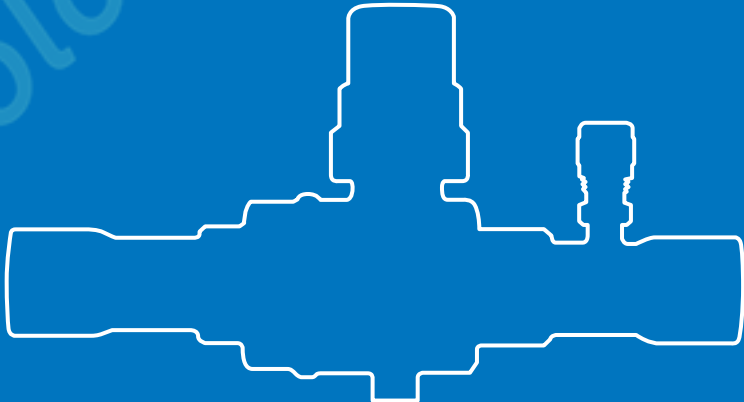

HANDBOOK
VALVES

Ed. 2017



CHAPTER 1 ■ VALVES WITH SCREW SHUTTER

FOR REFRIGERATION PLANTS THAT USE HCFC, HFC OR HFO REFRIGERANTS



APPLICATIONS

All valves illustrated in this chapter are designed for installation on commercial refrigeration systems and on civil and industrial air conditioning plants that use the following refrigerant fluids:

- HCFC (R22)
- HFC (R134a, R404A, R407C, R410A, or R507)
- HFO and HFO/HFC mixtures (R1234ze, R448A, R449A, R450A, or R452A)

belonging to Group 2, as defined in Article 13, Chapter 1, Point (b) of Directive 2014/68/EU, with reference to EC Regulation No. 1272/2008.

Furthermore, the valves (up to DN 25, for globe taps, model: 6512/9) can also be installed on systems using the following refrigeration fluids:

- HFC (R32)
- HFO (R1234yf)

classified as A2L in the ASHRAE 34-2013 standard, and belonging to Group 1, as defined in Article 13, Chapter 1, Point (a) of Directive 2014/68/EU, with reference to EC Regulation No. 1272/2008.

For specific applications with refrigerant fluids not listed above, please contact Castel Technical Department.

HERMETIC VALVES

The hermetic valves can be divided into two categories:

- Two-way shut-off valves, types 6010/2 and 6012/22
- Three-way valves; two main connections plus a third one for charging, types:
 - 6065, with right charge connection
 - 6075, with left charge connection

Note: the third way must be equipped with a mechanism (for example type 8394/A or other similar ones) to be ordered separately.

The main parts of the hermetic valves are made with the following materials:

- Hot forged brass EN 12420 – CW 617N for the body.
- Steel, with proper surface protection, or brass for the spindle
- Chloroprene rubber (CR) and aramid fibres for gland seal
- Glass-reinforced PBT for the protective cap that covers the spindle.

TABLE 1: General characteristics of valves for hermetic systems

Catalogue Number	Connections					Kv Factor [m ³ /h]	PS [bar]	TS [°C]		TA [°C]		Risk Category according to PED Recast
	SAE Flare			ODS				min.	max.	min.	max.	
	(1)	(2)	(3)	Ø [in.]	Ø [mm]							
6010/2	-	1/4"	1/4"	-	-	0,27	45	-40	-40	+50	Art. 4.3	
6012/22		1/4"	-	1/4"								
6020/222	1/4"	1/4"	1/4"	-	-	0,39	-40	-40	+50	+110	Art. 4.3	
6020/233		3/8"	3/8"			1,20						
6020/244		1/2"	1/2"			2,20						
6020/255		5/8"	5/8"			2,80						
6062/22M6		1/4"	-			6						0,46
6062/23M10		3/8"				10						1,38
6072/22M6		1/4"				6						0,46
6072/23M8		3/8"				8						1,29
6072/23M10		3/8"				10						1,38
6072/24M12		1/2"				12						2,55
6072/25M16	5/8"	16		3,40								

TABLE 2: Dimensions and weights of valves for hermetic systems

Catalogue Number	Dimensions [mm]									Weight [g]								
	H ₁	H ₂	H ₃	H ₄	H ₅	l	L ₁	L ₂	P ₁									
6010/2	14	66	-	-	-	36	-	58	-	-	160							
6012/22			29	55,5			145											
6020/222	25	51	61	115	-	-	62	-	-	-	360							
6020/233			60				67				370							
6020/244	26,5	52	67,5	127	-	-	77	-	-	-	520							
6020/255							79				530							
6062/22M6	25,5	31	56,5	-	1	-	25	72	30,5	-	205							
6062/23M10		33	58,5								200							
6072/22M6		31	56,5								205							
6072/23M8		33	58,5								-	1	-	25	72	30,5	-	210
6072/23M10																		220
6072/24M12		29,5	38,5								68	-	-	-	84	32	-	310
6072/25M16	39,5		69	320														

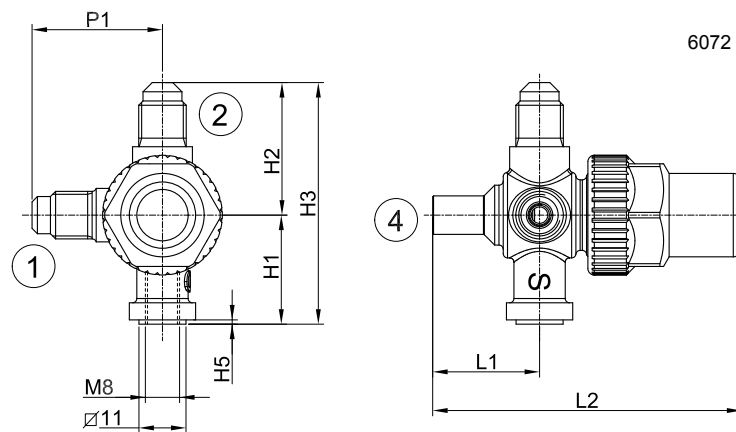
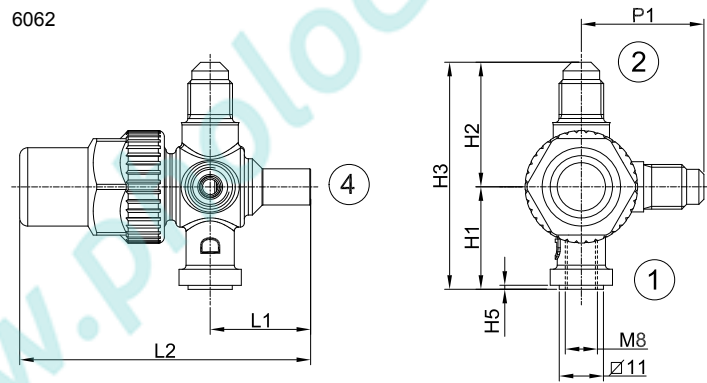
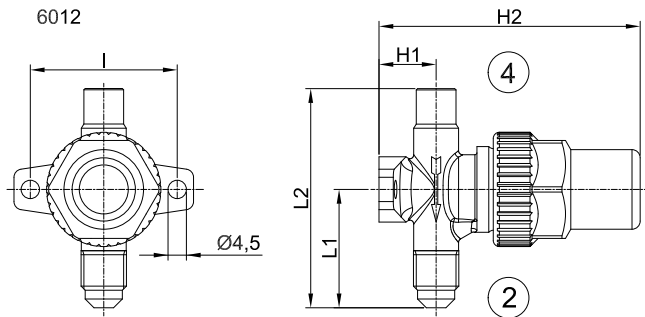
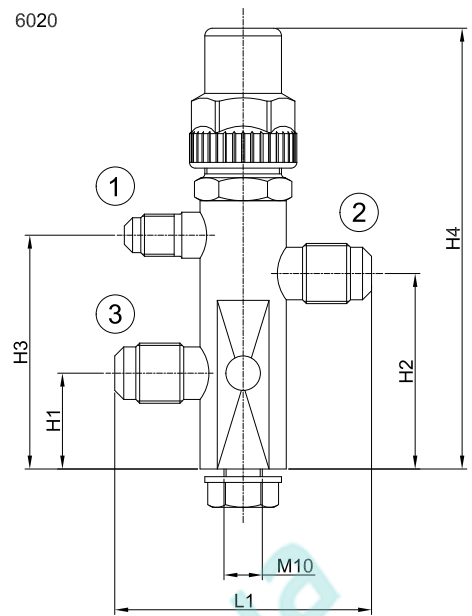
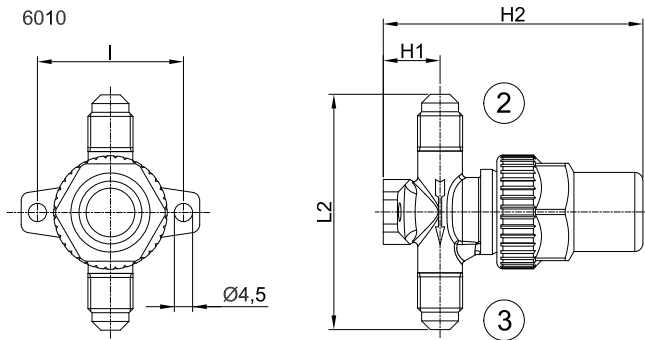

RECEIVER VALVES

The receiver valves can be divided into three categories:

- Two-way valves, 90° angle connections, types 6110 and 6120
- Three-way valves; two main connections (90° angle) plus a third one for charging, type 6132. The access connection may be shut off by the back-sealing of the spindle
- Two-way valves, 120° angle connections, type 6140

The main parts of the receiver valves are made with the following materials:

- Hot forged brass EN 12420 – CW 617N for the body.
- Steel, with proper surface protection, for the spindle.
- Chloroprene rubber (CR) and aramid fibres for gland seal
- Glass-reinforced PBT for the protective cap that covers the spindle.

TABLE 3: General characteristics of receiver valves

Catalogue Number	Connections			Kv Factor [m ³ /h]	PS [bar]	TS [°C]		TA [°C]		Risk Category according to PED Recast
	SAE Flare		NPT			min.	max.	min.	max.	
	(1)	(2)	(3)							
6110/21	-	1/4"	1/8"	0,44	45	-40	-40	+50	Art. 4.3	
6110/22		1/4"	1/4"							
6110/X15	1/4" F	1/4"	-							
6110/X11	-	-	1/4" M/F							
6110/23	-	1/4"	3/8"	0,45						
6110/32		3/8"	1/4"	1,35						
6110/33		3/8"	3/8"							
6110/X13		3/8" F	3/8"							-
6110/43	-	1/2"	3/8"							2,40
6110/44		1/2"	1/2"	3,40						
6110/54		5/8"	1/2"							
6110/66		3/4"	3/4"	6,00						
6120/22		1/4"	1/4"	0,44						
6120/23		1/4"	3/8"	0,45						
6120/32		3/8"	1/4"	1,35						
6120/33		3/8"	3/8"	1,35						
6120/43		1/2"	3/8"	2,40						
6120/44		1/2"	1/2"	3,40						
6120/54	5/8"	1/2"								
6120/66	3/4"	3/4"	6,00							
6132/22	1/4"	1/4"	1/4"	0,45		+110				
6132/33		3/8"	3/8"	1,20						
6132/44		1/2"	1/2"	2,20						
6132/54		5/8"	1/2"	3,85						
6140/22	-	1/4"	1/4"	0,36		+130				
6140/23		1/4"	3/8"							

TABLE 4: Dimensions and weights of receiver valves

Catalogue Number	Dimensions [mm]				Weight [g]	
	H ₁	H ₂	L ₁	L ₂		
6110/21	70,5	48	27,5	-	100	
6110/22	72				110	
6110/X15	83				130	
6110/X11	88	55,5	28,5		230	
6110/23	77	50	29		135	
6110/32			31		130	
6110/33			31		140	
6110/X13			87		175	
6110/43	88	55,5	34,5		220	
6110/44	92				235	
6110/54	92			245		
6110/66	128	88	42,5	675		
6120/22	27,5	-	72	48	110	
6120/23	30		77	50	130	
6120/32			80		135	
6120/33			80		140	
6120/43			93	225		
6120/44	33		55,5	94	305	
6120/54				94	245	
6120/66				129,5	88	670
6132/22	56		29	94	64	240
6132/33				97		250
6132/44	65,5	36	112	75	350	
6132/54			115		365	
6140/22	57	-	69	46	115	
6140/23					125	

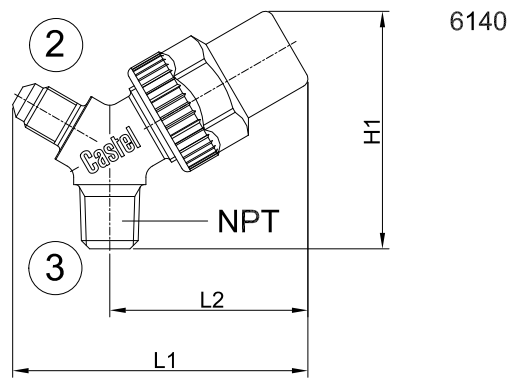
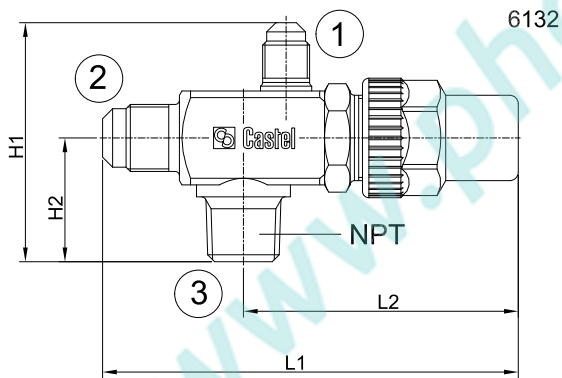
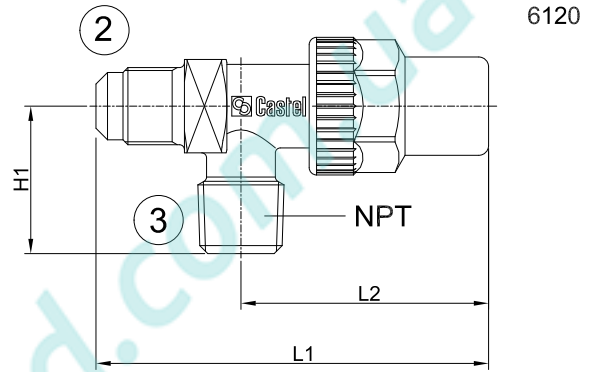
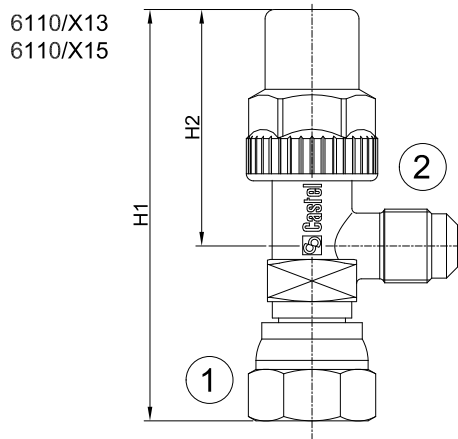
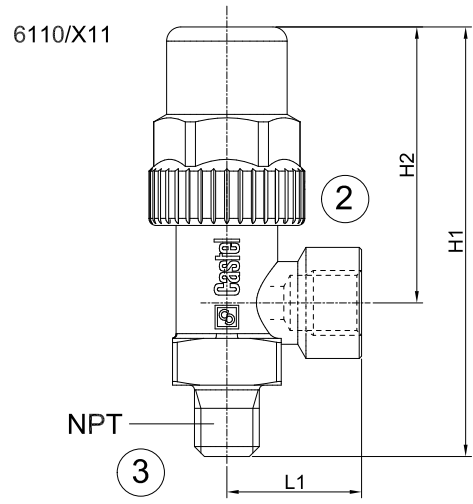
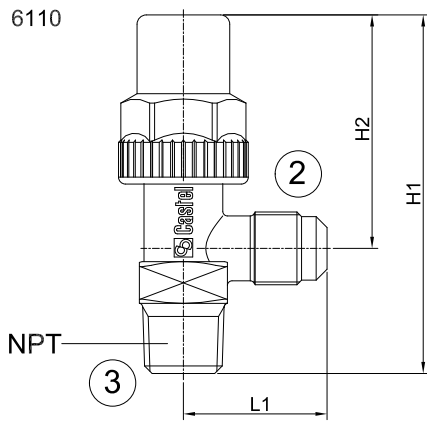

STOP VALVES

Stop valves have a very compact design and a fixing flange that is dimensioned to meet the current market requirements.

Valves 6170 and 6175 must be completed with the following components, which must be ordered separately:

- Internal spring mechanism, part no. 8394/B or external spring mechanism, part nos. 8395/A1 or 8395/A3
- Cap with gasket code 8392/A or 1/4" SAE FLARE blind union part no. 7020/20.

Valves 6176 6176 have been specifically designed to be installed on air conditioning systems that use R410A refrigerant fluid. They must be completed with the

following components, to be ordered separately:

- External spring mechanisms, part no. 8395/A1 and 8395/A3
- 5/16" SAE FLARE blind union, part no. 7020/X02

The main parts of the stop valves are made with the following materials:

- Hot forged brass EN 12420 – CW 617N for the body.
- Brass EN 12164 – CW 614N for spindle and protection cap
- Chloroprene rubber (CR) for outlet seal gaskets for series 6165, 6175 and 6176
- Chloroprene rubber (CR) and aramid fibres for gland seal, only for series 6170

TABLE 5: General characteristics of valves for split systems

Catalogue Number	Way Nr.	Connections				Kv Factor [m³/h]	PS [bar]	TS [°C]		TA [°C]		Risk Category according to PED Recast
		SAE Flare		ODS				min.	max.	min.	max.	
		(1)	(2)	Ø [in.]	Ø [mm]							
6165/22	2	-	1/4"	1/4"	-	0,68	45	-20	+110	-20	+50	Art. 4.3
6165/33			3/8"	3/8"		1,70						
6175/33	3	1/4"	3/8"	3/8"	-	1,70						
6175/44			1/2"	1/2"	3,40							
6175/55			5/8"	5/8"	16	4,60						
6170/66			3/4"	3/4"	-	9,00						
6170/77			7/8"	7/8"	-	10,80						
6176/44			3	5/16"	1/2"	1/2"						
6176/55	5/8"	5/8"			16	4,60						
6176/66	3/4"	3/4"			-	7,50						

TABLE 6: Dimensions and weights of valves for split systems

Catalogue Number	Dimensions [mm]								Weight [g]
	H ₁	H ₂	H ₃	D	L ₁	L ₂	L ₃	l	
6165/22	17	52	8	9,5	29	-	-	38	113
6165/33				12,7	30,5				120
6175/33				29	59,5	135			
6175/44	20	65	8	15,9	36	31	67	50	225
6175/55				19,0					235
6170/66	28,5	104	12	22,2	47	36	83	50	655
6170/77				28,6					670
6176/44	20	65	8	15,9	36	31	67	38	225
6176/55				19,0					235
6176/66				24	70				22,2

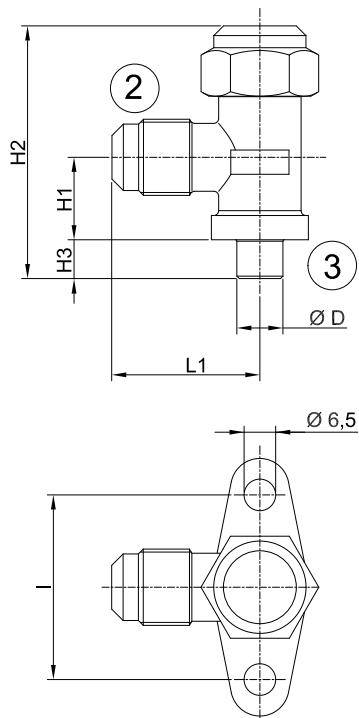

6165

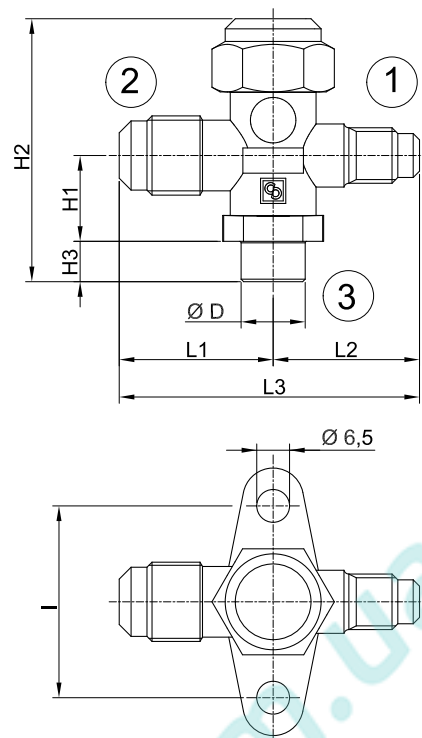

6170
6175
6176

DIAPHRAGM VALVES

Diaphragm valves do not have a gland seal. Thin metal discs (diaphragms), which hermetically isolate the spindle chamber from the fluid flow area, ensure the external sealing.

The main parts of the diaphragm valves are made with the

following materials:

- Hot forged brass EN 12420 – CW 617N for the body.
- Brass EN 12164 – CW 614N for spindle
- Harmonic steel for spring
- Nylon for seat sealing gaskets

TABLE 7: General characteristics of diaphragm valves

Catalogue Number	Connections			Kv Factor [m ³ /h]	PS [bar]	TS [°C]		TA [°C]		Risk Category according to PED Recast
	SAE Flare	ODS				min.	max.	min.	max.	
		Ø [in.]	Ø [mm]							
6210/2	1/4"	-	-	0,28	28	-35	+90	-35	+50	Art. 4.3
6210/3	3/8"			1,00						
6210/4	1/2"			1,30						
6210/5	5/8"			1,80						
6210/6	3/4"			3,65						
6220/M6	-	-	6	0,28						
6220/2		1/4"	-	1,00						
6220/3		3/8"	-							
6220/M10		-	10	1,30						
6220/4		1/2"	-	1,80						
6220/5		5/8"	16	3,65						
6220/6		3/4"	-	3,65						
6220/7		7/8"	-							

TABLE 8: Dimensions and weights of diaphragm valves

Catalogue Number	Dimensions [mm]						Weight [g]
	H ₁	H ₂	L ₁	d	l	D	
6210/2	68	53,5	58	4,5	36	52	200
6210/3	72		74		325		
6210/4			78		335		
6210/5			340				
6210/6	86	62,5	98	6,2	50	60	655
6220/M6	68	53,5	53	4,5	36	52	195
6220/2			72		61		38
6220/3	70				305		
6220/M10	71						
6220/4	86	62,5	92	6,2	50	60	580
6220/5			94				645
6220/7							

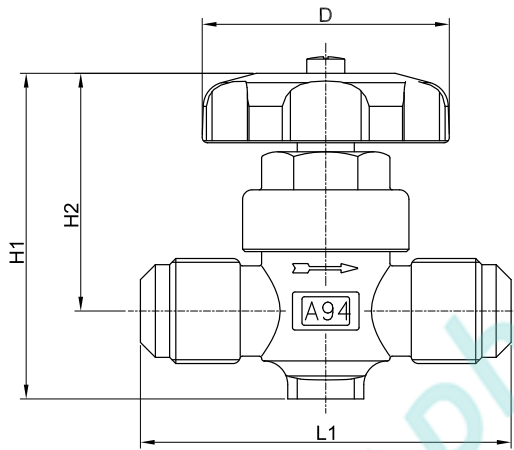

6210

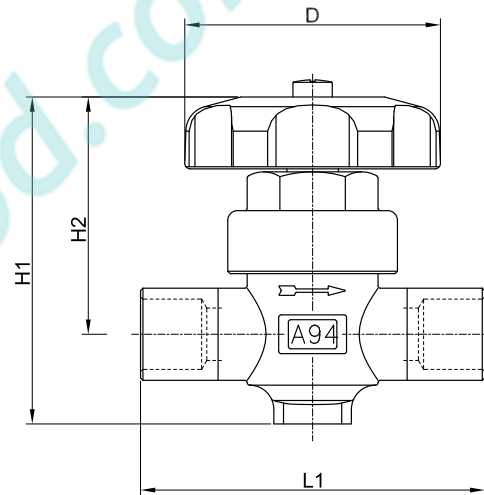

6220

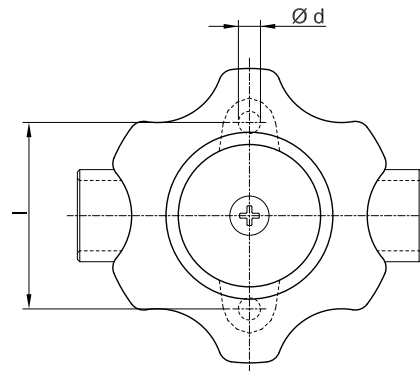
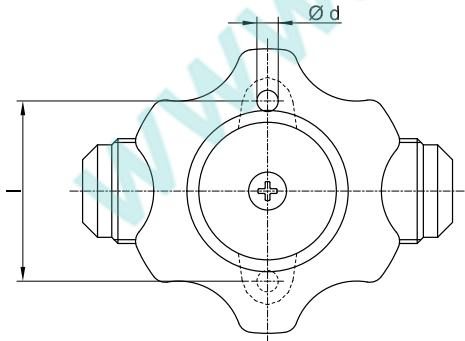

ROTALOCK VALVES

Rotalock valves mounted with 7910 fittings and 7990 gaskets, guarantee quick installation and safe sealing. They can be assembled in any direction before tightening the ring.

Furthermore, they have an additional charging connection, which can be excluded by the back sealing of the spindle.

Fittings 7910 and gaskets 7990 must be ordered separately. The main parts of the rotalock valves and their accessories are made with the following materials:

- Ottone forgiato a caldo EN 12420 – CW 617N per il corpo.
- Hot forged brass EN 12420 – CW 617N for the body.
- Steel, with proper surface protection, for the spindle and ring
- Chloroprene rubber (CR) and aramid fibres for gland seal
- Glass-reinforced PBT for the protective cap that covers the spindle.
- Steel bar EN 10277-3 11S Mn Pb 37 + C for 7910 fittings
- PTFE for 7990 gaskets

TABLE 9: General characteristics of rotalock valves

Catalogue Number	Connections			Union code	Gasket code	PS [bar]	Kv Factor [m ³ /h]	PS [bar]	TS [°C]		TA [°C]		Risk Category according to PED Recast
	SAE Flare		Swivel nut (3)						min.	max.	min.	max.	
	(1)	(2)											
6310/2	1/4"	1/4"	3/4" UNF	7910/6	7990/6	45	0,46	45	-40	+110	-40	+50	Art. 4.3
6310/3		3/8"					1,35						
6310/4		1/2"											
6320/3		3/8"	1" UNS	7910/8	7990/8		1,40						
6320/4		1/2"					3,10						
6320/5		5/8"											
6320/6		3/4"					3,4						

TABLE 10: Dimensions and weights of rotalock valves

Catalogue Number	Dimensions [mm]				Weight [g]	
	H ₁	H ₂	L ₁	L ₂		
6310/2	68,5	33,5	94	64	290	
6310/3						300
6310/4			97			
6320/3	69,5	34,5			330	
6320/4	72	36,5	114,5	77,5	400	
6320/5			117,5		415	
6320/6					425	

TABLE 11: Dimensions and weights of unions

Catalogue number	Connections			L	Weight [g]	Gasket code
	Threaded	Solder [mm]				
		ODF	ODM			
7910/6	3/4" UNF	10	13	26	28	7990/6
7910/8	1" UNS	-	19		47	7990/8

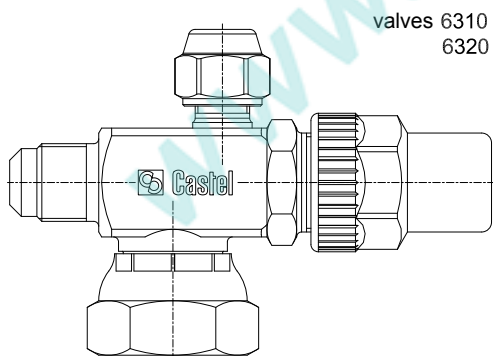

valves 6310
6320



gasket 7990

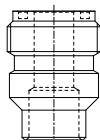

coupling 7910

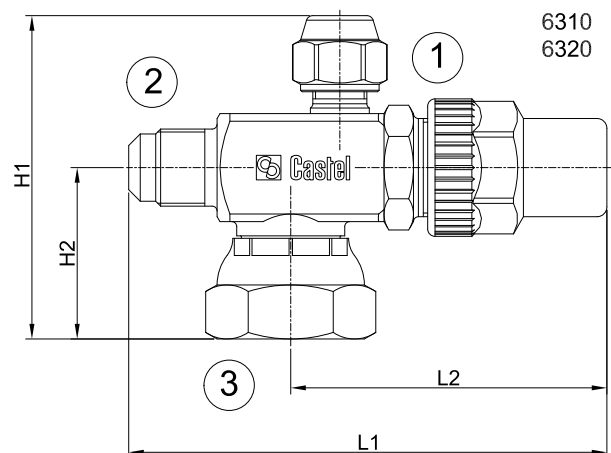

6310
6320

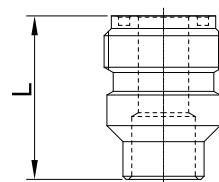

7910

CAPPED VALVES

The main parts of the capped valves are made with the following materials:

- Hot forged brass EN 12420 – CW 617N for the body
- Steel, with proper surface protection, for the spindle.
- Chloroprene rubber (CR) and aramid fibres for gland seal
- Glass-reinforced PBT for the protective cap that covers the spindle.

The brazing of capped valves with solder connections, type 6420, should be carried out with care, using a low melting point filler material. It is necessary to remove the spindle assembly, including the packing gland before brazing the body. It is important to avoid direct contact between the torch flame and the body, which could be damaged and compromise the proper functioning of the valves.

TABLE 12: General characteristics of capped valves

Catalogue Number	Connections			Kv Factor [m ³ /h]	PS [bar]	TS [°C]		TA [°C]		Risk Category according to PED Recast
	SAE Flare	ODS				min.	max.	min.	max.	
		Ø [in.]	Ø [mm]							
6410/2	1/4"	-	-	0,40	45	-40	+110	-40	+50	Art. 4.3
6410/3	3/8"			1,00						
6410/4	1/2"			1,45						
6410/5	5/8"			1,70						
6410/6	3/4"			3,50						
6420/2	1/4"			0,40						
6420/3	3/8"	1,00								
6420/3S3	3/8" - OUT		3/8" - IN							
6420/M10	-	-	10	1,45						
6420/M12		-	12							
6420/4		1/2"	-							
6420/5		5/8"	16	1,70						
6420/M18		-	18	3,50						
6420/6		3/4"	-							
6420/M22		-	22							
6420/7		7/8"	-							

TABLE 13: Dimensions and weights of capped valves

Catalogue Number	Dimensions [mm]					Weight [g]
	H ₁	H ₂	L ₁	d	l	
6410/2	85,5	67	68	4,5	38	305
6410/3			74			325
6410/4			78			330
6410/5			78			330
6410/6	113	89,5	98	6,2	50	695
6420/2	85,5	67	57	4,5	38	300
6420/3			61			305
6420/3S3			67,5			
6420/M10			61			
6420/M12			70			
6420/4			71			
6420/5			71			
6420/M18			113			89,5
6420/6	94	685				
6420/M22	94	690				
6420/7	94					

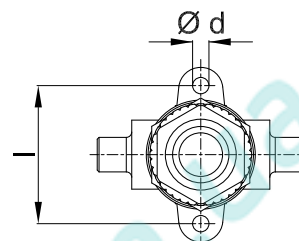
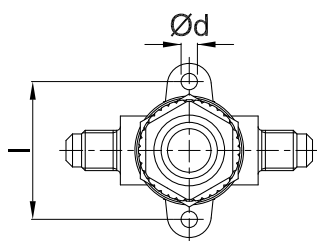
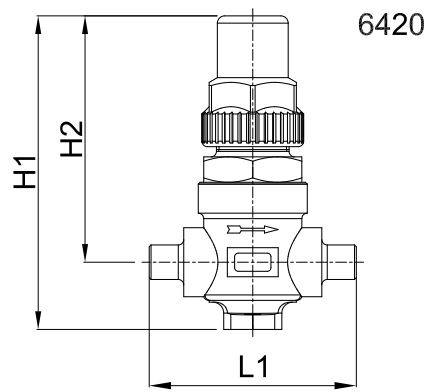
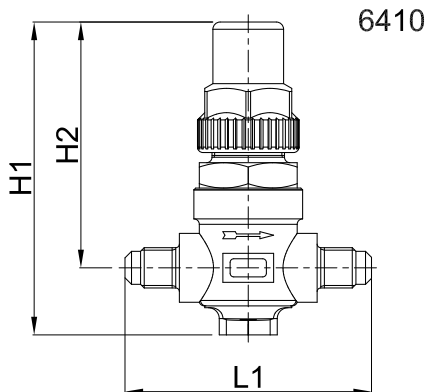

GLOBE VALVES

These valves are available in the following two types:

- 6512 with straight solder connections
- 6532 with right-angle solder connections

The main parts of the globe valves are made with the following materials:

- Hot forged brass EN 12420 – CW 617N for body, cover and cap that covers the spindle
- Steel, with proper surface protection, for the spindle.
- Chloroprene rubber (CR) and aramid fibres for gland seal
- Metal-rubber laminate for outlet seal gaskets
- PTFE for seat gaskets.

TABLE 14: General characteristics of globe valves

Catalogue Number	Connections				Kv Factor [m ³ /h]	PS [bar]	TS [°C]		TA [°C]		Risk Category according to PED Recast
	ODS		ODM				min.	max.	min.	max.	
	Ø [in.]	Ø [mm]	Ø [in.]	Ø [mm]							
6512/M22	–	22	–	28	7,1	45	-35	+160	-35	+50	Art. 4.3
6512/7	7/8"	–	1.1/8"	–							
6512/M28	–	28	1.3/8"	35	8,4						
6512/9	1.1/8"	–	1.3/8"	35							
6512/11	1.3/8"	35	1.5/8"	–	15,0						
6512/13	1.5/8"	–	2"	–	25,0						
6512/M42	–	42	2"	–							
6512/17	2.1/8"	54	–	–	40,0						
6532/M22	–	22	–	28	8,2						
6532/7	7/8"	–	1.1/8"	–							
6532/M28	–	28	1.3/8"	35	9,1						
6532/9	1.1/8"	–	1.3/8"	35							
6532/11	1.3/8"	35	1.5/8"	–	18,7						
6532/13	1.5/8"	–	2"	–	38,0						
6532/M42	–	42	2"	–							
6532/17	2.1/8"	54	–	–	48,5						

TABLE 15: Dimensions and weights of globe valves

Catalogue Number	Dimensions [mm]						Weight [g]
	H	H1	L	L1	Q	A	
6512/M22	136	28,5	100	-	60	94	1415
6512/7							1310
6512/M28							
6512/9							
6512/11	166	34	118	-	68	126	2020
6512/13	199	37	141	-	88	138	3500
6512/M42							5050
6512/17	215	42,5	173	-	104	-	
6532/M22	147	44,5	80	50	60	94	1350
6532/7							1290
6532/M28							
6532/9							
6532/11	165	52,5	93	59	68	126	1910
6532/13	238	65	139	86,5	104	138	4920
6532/M42							4765
6532/17							

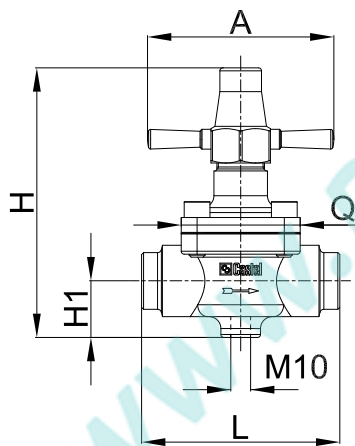

6512

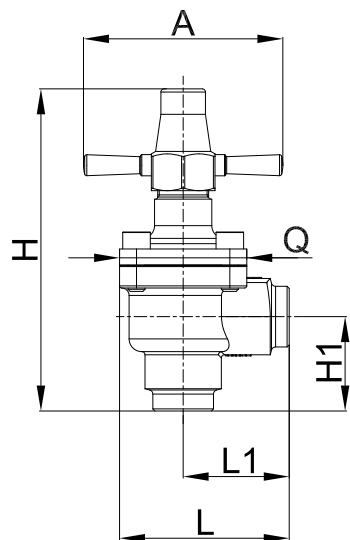

6532

GAUGE MOUNTING VALVES

The valves are equipped with:

- A small flange for fixing the tap to the control panel
- A threaded SAE Flare connection for joining it to the copper pipe with a union.
- A threaded NPT (type 8320) or a swivel union SAE Flare (8321) connection for mounting the gauge

The main parts of the gauge mounting valves are made with the following materials:

- Hot forged brass EN 12420 – CW 617N for the body
- Steel, with proper surface protection, for the spindle.
- Chloroprene rubber (CR) and aramid fibres for gland seal
- Glass-reinforced PBT for the protective cap that covers the spindle.

TABLE 16: General characteristics of gauge mounting valves

Catalogue Number	Connections			Kv Factor [m³/h]	PS [bar]	TS [°C]		TA [°C]		Risk Category according to PED Recast
	SAE Flare	NPT	SAE Flare			min.	max.	min.	max.	
8320/21	1/4"	1/8"	–	0,44	45	-40	+130	-40	+50	Art. 4.3
8320/22	1/4"	1/4"	–							
8321/22	1/4"	–	1/4" f							

TABLE 17: Dimensions and weight of gauge mounting valves

Catalogue Number	Dimensions [mm]				Weight [g]
	H1	L1	L2	L3	
8320/21	19	83	35	17	140
8320/22	37				186
8321/22	40				

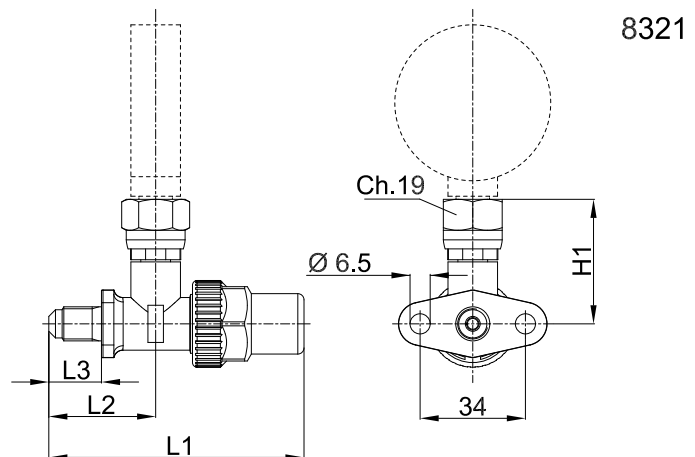
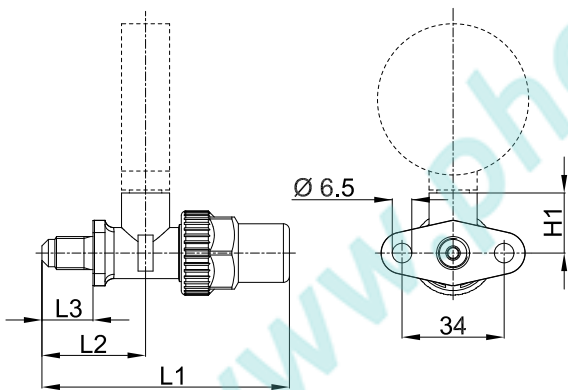

LINE PIERCING VALVE

The piercing valve is a fast, economic means of providing a charging, purging or gauge inlet point in the refrigeration system. It can be applied on copper pipes with a 6 mm to 10 mm diameter, and can be installed in any position on the system.

The main parts of the piercing valve are made with the following materials:

- Hot forged brass EN 12420 – CW 617N for the body
- Hardened steel for the needle
- Chloroprene rubber (CR) for the outlet seal gaskets

Install the threaded fork astride of the copper pipe, fix the valve to the pipe, tightening the lower nut. Then, as the needle advances, it pierces the pipe. The hole connects the inside of the pipe with the 1/4" SAE Flare connection of the valve as shown in Figures 1 and 2.

TABLE 18: General characteristics and dimensions of line piercing valve

Catalogue Number	Connections		Dimensions [mm]				Weight [g]	PS [bar]	TS [°C]		TA [°C]		Risk Category according to PED Recast
	SAE Flare	Pipe Diameter [mm]	H ₁	H ₂	L ₁	L ₂			min.	max.	min.	max.	
8330/A	1/4"	6 - 10	72	25,5	29	36	104	25	-10	+70	-10	+50	Art. 4.3

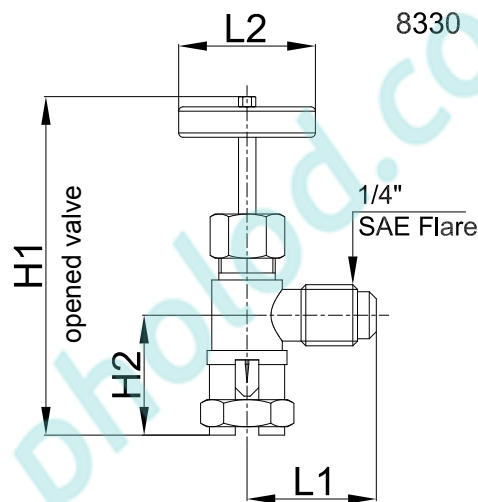

www.castel.it



ed. 002-VR-ENG

Castel can accept no responsibility for any errors or changes in the catalogues, handbooks, brochures and other printed material. Castel reserves the right to make changes and improvements to its products without notice. All trademarks mentioned are the property of their respective owners.
The name and Castel logotype are registered trademarks of Castel Srl.
All rights reserved.

Castel Srl - Via Provinciale 2-4 - 20060 Pessano con Bornago - MI