

SEMI-HERMETIC RECIPROCATING

Two-Stage Compressor Series

50Hz

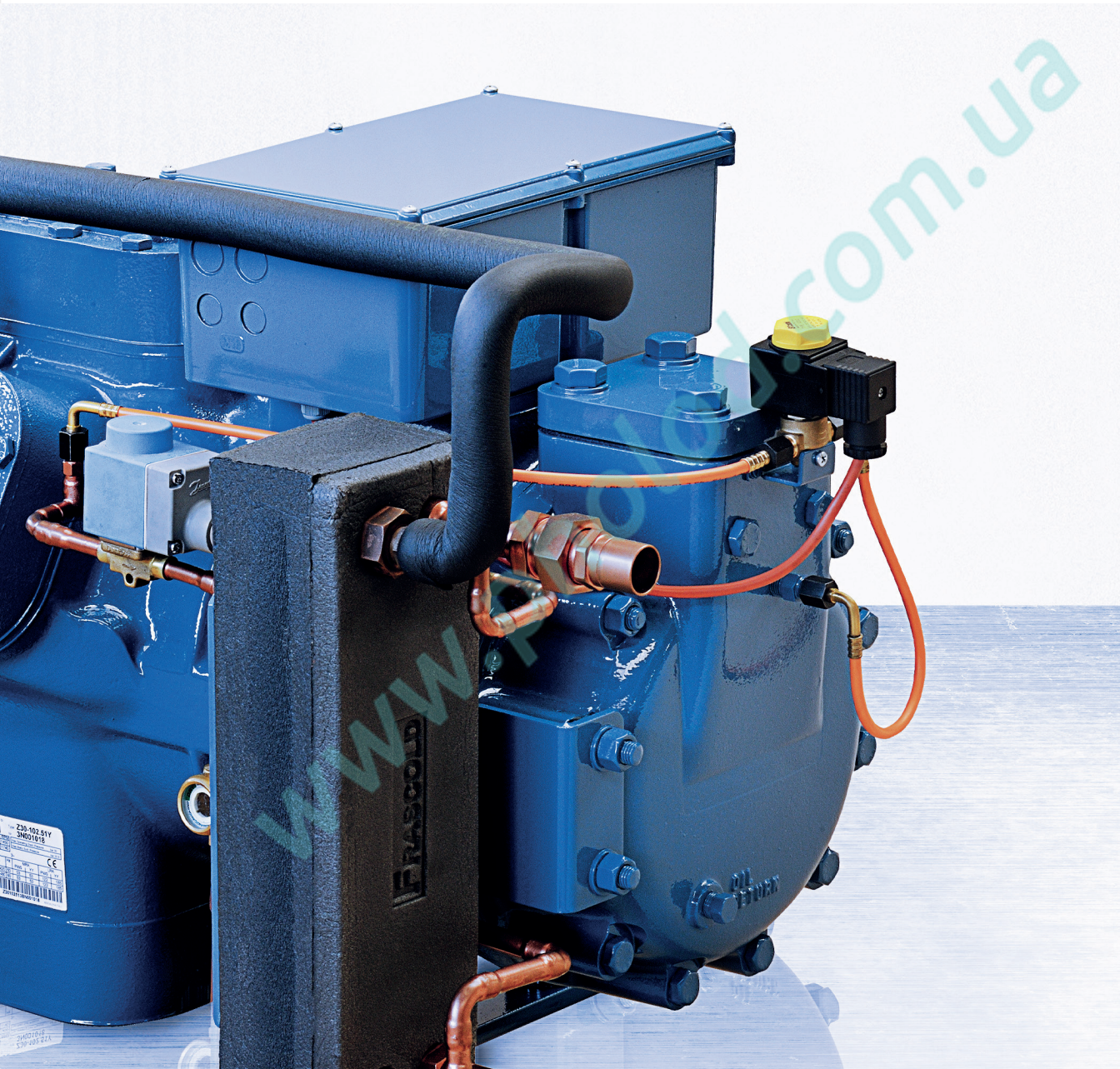

INDEX

4	About the Company
5	Segments and Solutions
6	Product information
16	Technical Data & Operating Limits
20	Technical Drawings and Dimensions
31	Contact us

ABOUT THE COMPANY

Frascold manufactures over 70,000 screw and reciprocating compressors a year. Our 53,000 m² factory outside of Milan (Italy) houses our advanced engineering, manufacturing and testing facilities. More than 200 employees work in the Headquarters and in the Subsidiaries based in the United States, China and India, with distribution partners and service centers in 86 countries.

The infographic is a 3D-style illustration with four numbered callouts. Callout 1 shows a large industrial factory building. Callout 2 shows a group of people icons. Callout 3 shows a large number of truck icons. Callout 4 shows a world map with several flags and a laptop computer.

53.000 sqm factory outside Milan (Italy) hosting our advanced engineering manufacturing and testing facilities. ①

More than 200 employees working in Italy, China, India and United States. ②

Over 70.000 screw and reciprocating compressors manufactured every year. ③

Distribution partners and service centers in 86 countries. ④

More than 80 years ago Frascold born as a small family owned Company developing solutions in refrigeration and conditioning industry. Today we invest more and more in people, products, technologies and services aiming to become the best partner for our Customers and the touchstone for the market.

GIUSEPPE GALLI - Frascold Executive Managing Director

SEGMENTS



COMFORT



COMMERCIAL & TRANSPORT REFRIGERATION



INDUSTRIAL REFRIGERATION



PROCESS COOLING

SOLUTIONS

Cooling capacity range @50Hz



SCREW COMPRESSORS



RECIPROCATING COMPRESSORS



CONDENSING UNITS

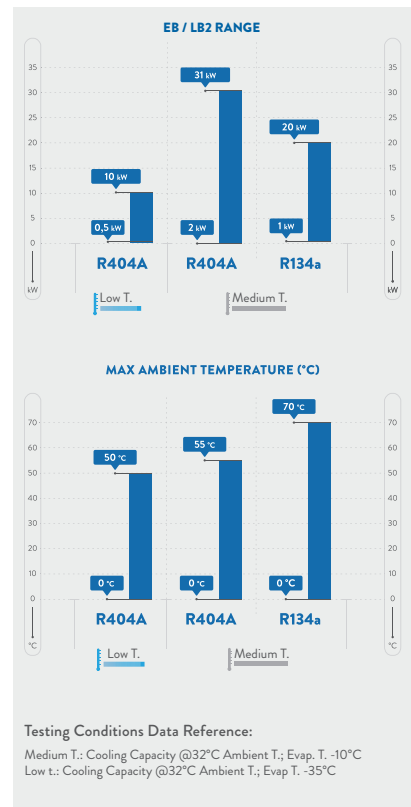
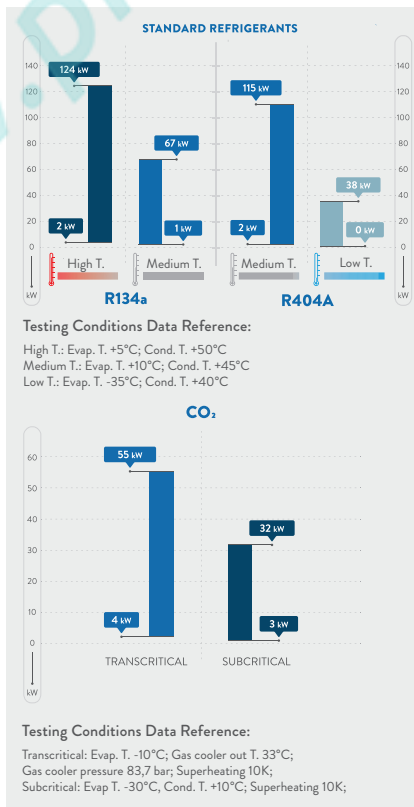
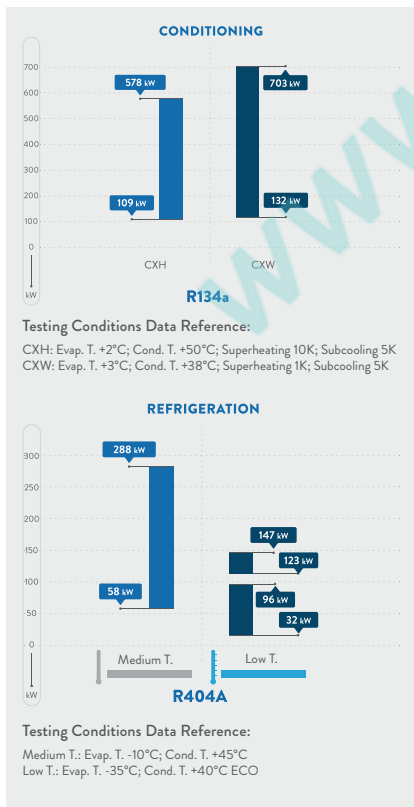



TWO-STAGE RECIPROCATING COMPRESSORS

Fracold two-stage compressors models S 2V and 2Z, have been redesigned and re-engineered by eliminating external conduits for interstage circuitry and including an additional liquid injection system.

MAIN FEATURES



Compact Design

Thanks to the elimination of external conduits, the compressor features reduced dimensions.



Reliable & Sturdy

The new specially designed components make the compressor resistant to all operating conditions within its working range.



Sub-cooler Kit

All models can be fitted with a pre-assembled sub-cooler that can be provided installed and connected or supplied separately.



Optimized Liquid Injection

The compressed gas and injected liquid mixing process is instantaneous and the liquid is not overheated as it does not go through the motor.



Exclusive motor Cooling System

The motor is injected solely with the exact amount of fluid required to cool the motor. This system, only available on Frascold compressors, prevents the formation of ice on the motor by eliminating damage by oxidation, by condensate in the electrical box and liquid slugging.



Increased Efficiency

Special bearings have been designed with a cage that helps reduce noise levels and increase the load coefficient and their operating life.



Silent Operation

Thanks to the dual liquid injection, purposely designed to optimise the operation of the compressor to achieve maximum performance.

CONFORMITY DECLARATION

Frascold Two-stage reciprocating compressors are intended for installation in refrigeration systems. The machine or partly completed machines shall comply with local safety regulation and standards of the place of installation (within the EU according to the EU Directives 2006/42/EC Machinery Directive, 2014/68/UE Pressure Equipment, 2006/95/EC Low Voltage Directive). They may be put into operation only if the compressor has been installed in accordance with these assembly instructions.

Commissioning is only possible if the entire system into which it is integrated has been inspected and approved in accordance to the provisions of legal regulations.

The Manufacturer Declaration describes the standards to be applied. The Manufacturer Declaration of incorporation, according to the 2006/42/EC, is available at: www.frascold.it, documentation, manufacturer's declaration.

8 PERFORMANCE DATA FSS3 SOFTWARE

Please refer to our FSS3 to check performances of all our compressors.

①	②	③	④	⑤	⑥	⑦	⑧
① Operating limits	② Cooling capacity	③ All operating data with any kind of refrigerant	④ European standard EN12900 at 50Hz	⑤ Technical information	⑥ Drawings	⑦ Manuals	⑧ Catalogues and certifications

ASERCOM CERTIFICATION

ASERCOM (Association of European Refrigeration Component Manufacturers) promotes standards for safety and performance ratings in the refrigeration industry. ASERCOM certification means that a compressor's performance has been determined to meet the specifications stated by its manufacturer.

Manufacturer's performance data for a particular compressor model and refrigerant are submitted to ASERCOM for certification. To ensure objectivity, members of the certification committee are selected from competing manufacturers. If the committee agrees with the submitted performance data that model is added to the certified list.

Models from the certified list are regularly tested to verify performance. To ensure fairness, the compressor to be tested is obtained from a distributor's stock and tested at a competitor's facility. If test results are not up to listed specifications that model is removed from the certified list.



Frascold stands behind the quality, performance and reliability of all of our products. We currently have 108 ASERCOM certified models and more on the way. All of our compressors are run tested at the factory and carry a standard 2 year warranty.

COOLING CAPACITY

Range @50Hz

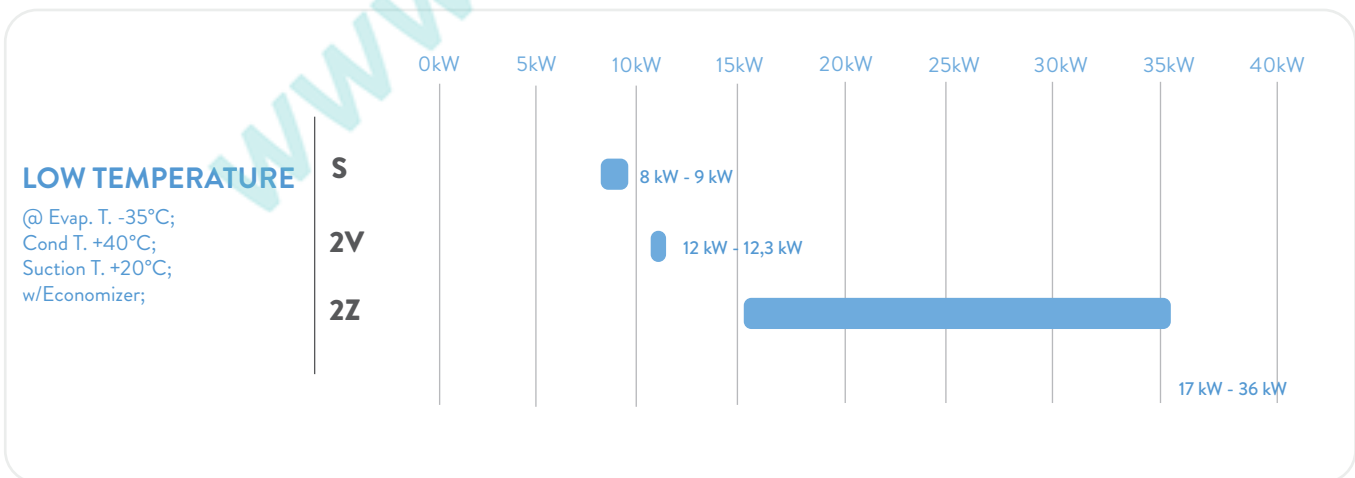

LEGAL DISCLAIMER:

While Frascold has made every effort at the time of publication to ensure the accuracy of the information provided herein, product specifications and performances could be subject to change without notice. You can find the most updated information in our Product Selection Software FSS3 at the link: https://www.frascold.it/en/download/software/fss_3_frascold_selection_software

PRODUCT RANGE

TWO STAGE RECIPROCATING

4 Cylinders **2** Models
1st stage: 26 - 27 m³/h
2nd stage: 16 - 19 m³/h
5 - 7 HP

S SERIES

2V SERIES

4 Cylinders **1** Model
1st stage: 42 m³/h
2nd stage: 29 m³/h
10 HP

2Z SERIES

6 Cylinders **4** Models
1st stage: 60 - 123 m³/h
2nd stage: 30 - 62 m³/h
15 - 40 HP

MODEL DESIGNATION

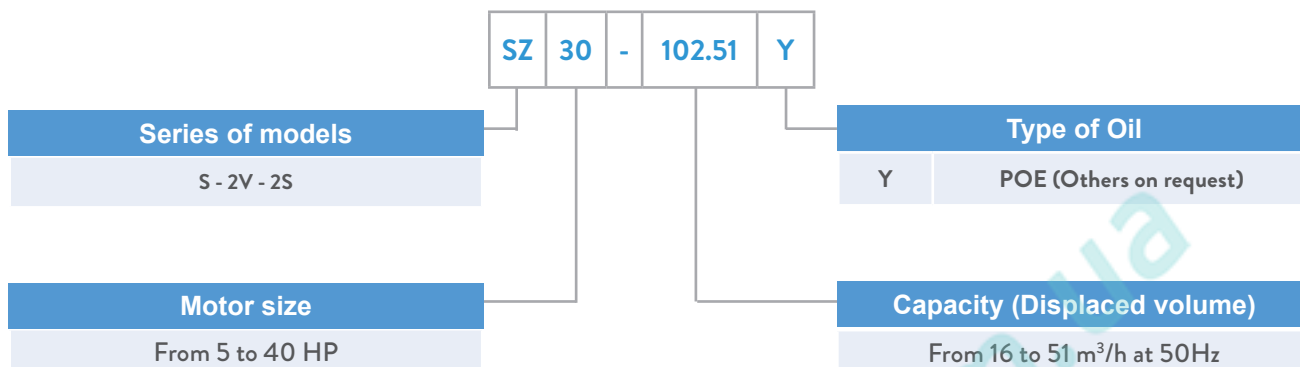

INFORMATION PLATE

All the important information to identify the compressor is displayed on the plate. The date of production is contained in the serial number. The indication of the type of coolant is the installer's responsibility.

The information plate contains the following details:

- Capacity (displaced volume in m³/h):**

Hz	Displ. m ³ /h	RPM
50	51/103	1450
60	62/124	1740
- Type of lubricant oil:** Oil type: POE32 3~
- Electrical data:**

Volt		Hz	MRA		LRA	
PWS	YY	Hz	PWS	YY	PWS	YY
380-420	380-420	50	53	53	132,6	224,4
440-480	440-480	60	53	53	132,6	224,4
- Compressor model:** 2Z30-102.51Y
- Serial number:** 3P001001
- Maximum operating pressures:**
 - Max. Operating Disch. Pressure: bar 30
 - Max. Static Suct. Pressure: bar 20,5
- Label certifying the conformity with European safety requirements:** EAC CE
- Bar code (Compressor identification number):** 2Z30 3AP001001
- Manufacturing site:** RESCALDINA ITALY

STANDARD EQUIPMENT AND OPTIONAL ACCESSORIES

TWO-STAGE RECIPROCATING COMPRESSORS

Motor power supply

S, 2V & 2Z

4/6 Cylinders with integrated part-winding
 Start-up electric motor
 380 - 420 V / 3 / 50Hz
 440 - 480 V / 3 / 60Hz
 Electrical motor with PTC sensor





12

Description	S		2V				2Z					
	Std.	Opt.	1	2	Std.	Opt.	1	2	Std.	Opt.	1	2
Electrical connections box	•				•				•			
Discharge temperature probe	•				•				•			
High and low pressure safety valves	•				•				•			
Intake and compression valves	•				•				•			
Oil charge POE 32 cSt	•				•				•			
Protective nitrogen charge	•				•				•			
Oil level visual indicator	•				•				•			
Oil heating resistance		•				•				•		
Rubber vibration dampers	•				•				•			
Electronic oil level switch			n.a			•				•		
Electronic oil level regulator		•				•				•		
Sub-cooler		•				•				•		
Injection Control Card			n.a		•					•		
INT69 Diagnose control and protection device	•						•				•	
INT69 TML Diagnose control and protection device (only with Direct Control)		n.a						•				•
Electronic differential pressure switch to control lubrication Delta P-II (only with Standard Control and Diagnostic Control)		n.a			•			•	•			
Electronic differential pressure switch to control lubrication INT250FR (only with Direct Control)		n.a			•			•	•			
Modbus application	•					•				•		

1. Only with diagnose control 2. Only with direct control

MOTOR COOLING SYSTEM

Here are the features of the device:

- 
Constant and accurate control of the motor temperature
 The system accurately and constantly checks the temperature via the AMS sensors located inside the windings. Indeed, the position of the sensors has been specifically designed to identify the most critical areas in terms of overheating, thereby allowing to protect the motor also during the critical start-up stage.
- 
Efficient motor cooling
 The system identifies when the pre-alarm temperature threshold is reached and activates the injection of liquid in the motor according to optimised amounts and time.
- 
Compressor reliability
 The controlled cooling of the motor prevents excessive cooling on neighbouring areas, eliminating the risk of frost and resulting oxidation, thereby preventing the formation of condensation in the electrical box of the compressor and the risk of a short circuit.
- 
Prevention of motor overheating
 The system identifies when the critical temperature threshold has been reached and stops the compressor in the event of anomalous overheating.
- 
Liquid injection monitoring
 Thanks to the TA device installed as standard, as well as injecting the liquid as required, the system can prevent this function when the compressor stops due to a malfunction of the compressor itself or due to external system management logics.

The ICC module is supplied as standard and already fully wired inside the electrical box.

Injection Control Card

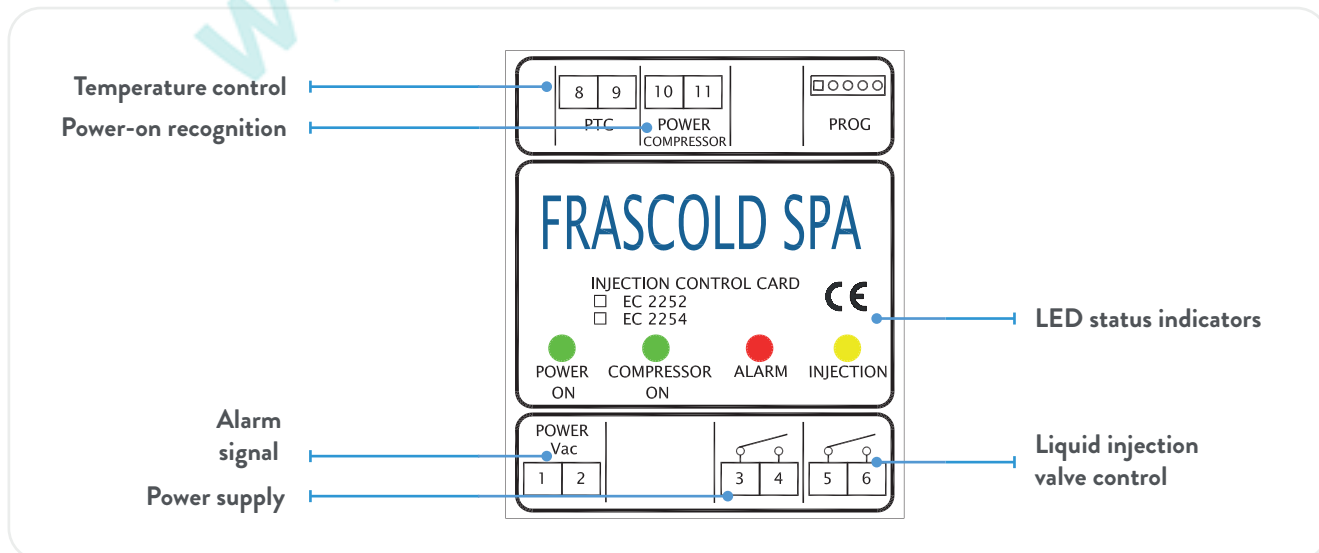

CONTROL AND PROTECTION DEVICE INT69® DIAGNOSE AND INT69 TML ® DIAGNOSE

Kriwan Diagnose devices are a further development of compressors' protection units. The Diagnose technology is not only limited to protecting the compressor, but also offers diagnosis and system optimisation features; providing detailed information to technicians in order to promptly diagnose any plant problems; it even makes it possible to prevent malfunctioning before it occurs thanks to data analysis. The additional protection features help extending the compressor's service life. Through this technology applied to compressors, users will benefit from enhanced reliability of the cooling system and from the reduction in running and maintenance costs. Frascold was the first compressor manufacturer to adopt this innovative technology and today it is standard on all our compressors.

Advantages:

- Guaranteed optimal operation throughout the compressor's entire life cycle.
- Convenient and with straightforward operation.
- Instantaneous diagnosis and precise problem-solving in case of error or fault.
- Specifically adapted to the user's needs.
- Intelligent monitoring of compressor operation.
- It extends the operative life of cooling systems.
- Improves compressor protection.
- Reduces running and maintenance costs.
- Automatic storage of operative data and errors in a memory.
- Technical card with retrieval of stored data.
- Display of compressor status through flash LED code.
- Data download through USB connection.
- Remote communication through Modbus-Gateway and LAN-Gateway protocol.
- Also applicable to previously installed compressors.

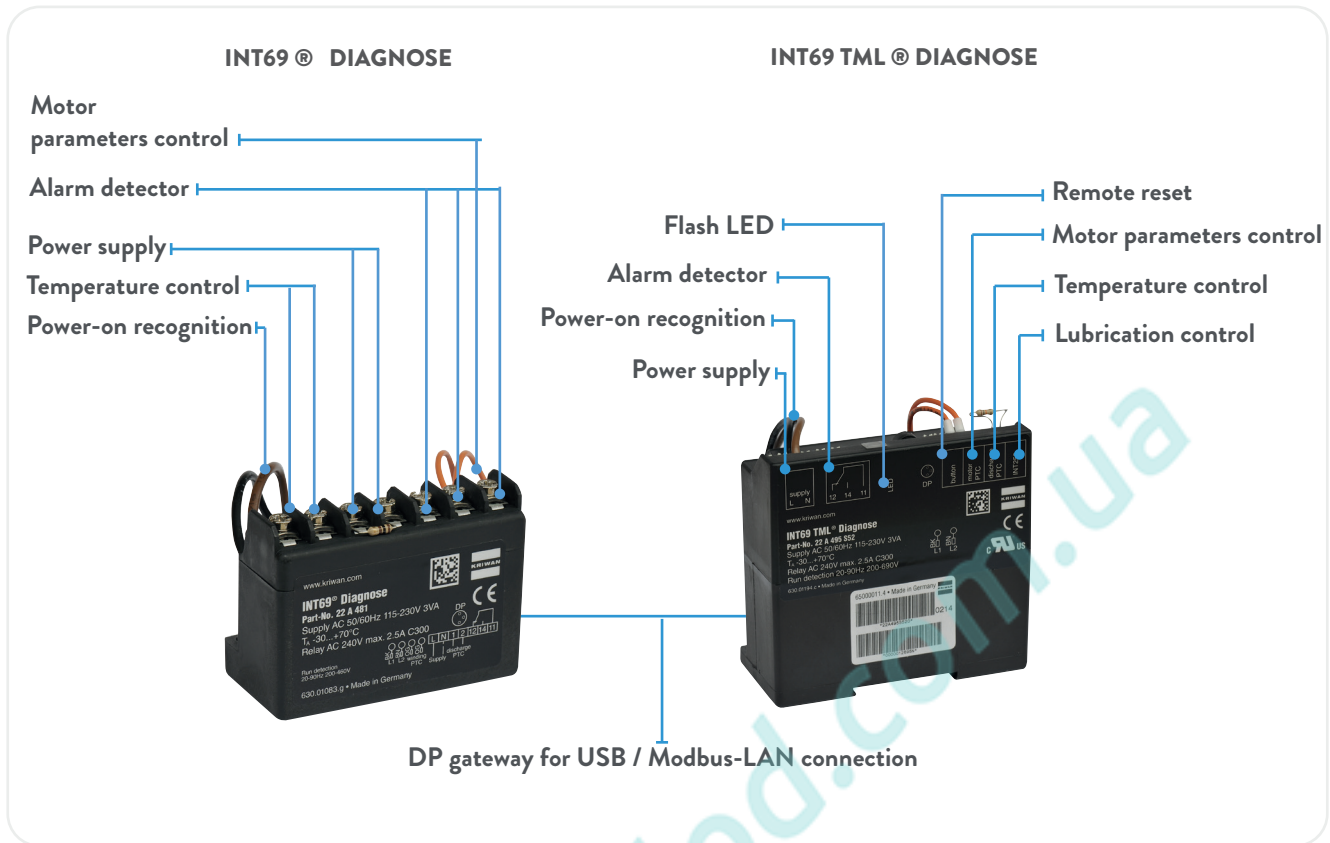

*INT69® Diagnose is intellectual property and trademarks ® of KRIWAN Industrie-Elektronik GmbH.

Control	Protection device			Differential pressure switch		Operating Limits
	Fracold ICC Module	Kriwan INT69 Diagnose	Kriwan INT69 TML Diagnose	Delta/P-II	INT250FR	

Standard Control	•			•		The Differential Oil Pressure Switch (supplied) communicates directly with the Central Control Panel (PCC) of the system. The ICC module sends alarm signals directly to the PCC
Diagnostic Control (optional)	•	•		•		The Differential Oil Pressure Switch (supplied) communicates directly with the Central Control Panel (PCC) of the system. The ICC module sends alarm signals to the INT69 module. Diagnose (supplied as standard and to be installed on the electrical panel of the PCC) to allow for diagnostics on the compressor (alarm log, start-up sequences, etc.).
Direct Control (optional)	•		•		•	The Differential Oil Pressure Switch (provided as standard) communicates with the INT69TML Diagnose module (provided as standard and to be installed in the electrical panel of the PCC). The INT69ML Diagnose module performs full diagnostics of the compressor (alarms log, start-up sequences, etc.), by acquiring the alarm signals both from the ICC and the INT250 FR pressure switch.

TECHNICAL DATA AND OPERATING LIMITS

Two-stage Reciprocating Compressors Series

LEGAL DISCLAIMER:

While Frascold has made every effort at the time of publication to ensure the accuracy of the information provided herein, product specifications and performances could be subject to change without notice. You can find the most updated information in our Product Selection Software FSS3 at the link: https://www.frascold.it/en/download/software/fss_3_frascold_selection_software



**TWO-STAGE
@50Hz**

Motor power supply
380V-420V / 3 / 50Hz
440V-480V / 3 / 60Hz

Models	Cylinders		Displacement 1		Oil Charge 2	Electrical Data 3			Line connection 4				Weight 5
	LP	HP	LP	HP		Max Operating current 400V	Max absorbed current 400V	Locked rotor current 400V	Suction		Discharge		
									[m ³ /h]	[m ³ /h]	[dm ³]	[A]	
S5-26.16Y	2	2	25,2	16,4	2,9	14,0	8,3	35,5	1 ³³ / ₈ "	35	7 ⁷ / ₈ "	22	120
S7-27.19Y	2	2	26,9	19,1	2,9	18,0	9,5	47,0	1 ³³ / ₈ "	35	7 ⁷ / ₈ "	22	122
2V10-42.29Y	2	2	41,9	29,4	4,0	23,0	13,5	53,9	1 ³³ / ₈ "	35	1 ³³ / ₄ "	28,6	173
2Z15-60.30Y	4	2	58,8	29,4	7,2	31,0	17,0	74,8	1 ³³ / ₈ "	42	1 ³³ / ₄ "	35	220
2Z20-72.36Y	4	2	70,8	35,4	7,2	37,0	20,9	107,0	1 ³³ / ₈ "	42	1 ³³ / ₄ "	35	225
2Z25-84.42Y	4	2	83,8	41,9	7,2	45,0	25,8	118,0	1 ³³ / ₈ "	42	1 ³³ / ₄ "	35	230
2Z30-102.51Y	4	2	102,9	51,5	7,2	53,0	30,9	133,0	1 ³³ / ₈ "	42	1 ³³ / ₄ "	35	239
2Z35-112.56Y	4	2	112,1	56,1	7,2	60,02	36,1	144,5	1 ³³ / ₈ "	42	1 ³³ / ₄ "	35	245
2Z40-123.62Y	4	2	123,1	61,6	7,2	71,9	41	159,2	1 ³³ / ₈ "	42	1 ³³ / ₄ "	35	250

1 Conversion factor for 60Hz = 1.2.

2 Oil charge POE 32 cSt. We always recommend using the heating element.

3 The reported value refers to operation at 50Hz.

Operation at 60Hz multiply by 1.2. The max operating current remains unchanged.

The size of the contactors, cables and fuses must take into account the maximum operating temperature and the maximum power absorbed. AC3 category contactors.

4 Connections of weld-on valves.

5 Net weight including: valves, oil charge, rubber dumpers.

± 10% with reference to the average value of the voltage field. Other voltage values provided upon request.

Find the most updated information in our Product Selection Software FSS3 at the link :

https://www.frascold.it/en/download/software/fss_3_frascold_selection_software

Operating Limits

R404A - R507A

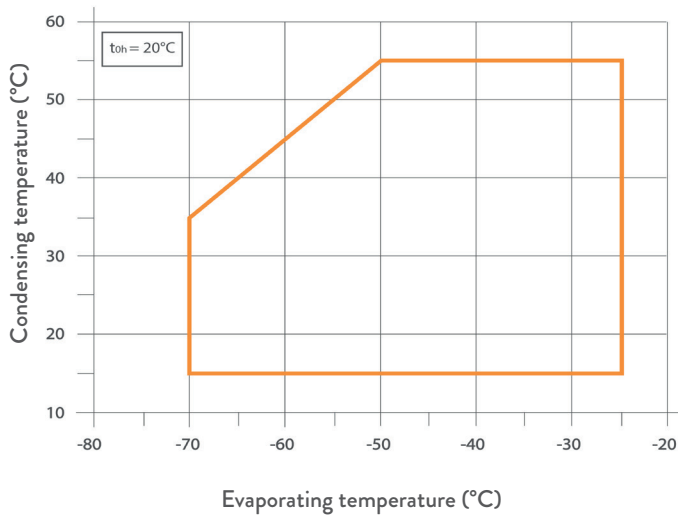

Standard application diagram

Check the envelope of each compressor model in the Frascold Selection Software program

www.pholod.com.ua

TECHNICAL DRAWINGS AND DIMENSIONS

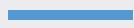

Two-stage Reciprocating Compressors Series

www.pholod.com.ua

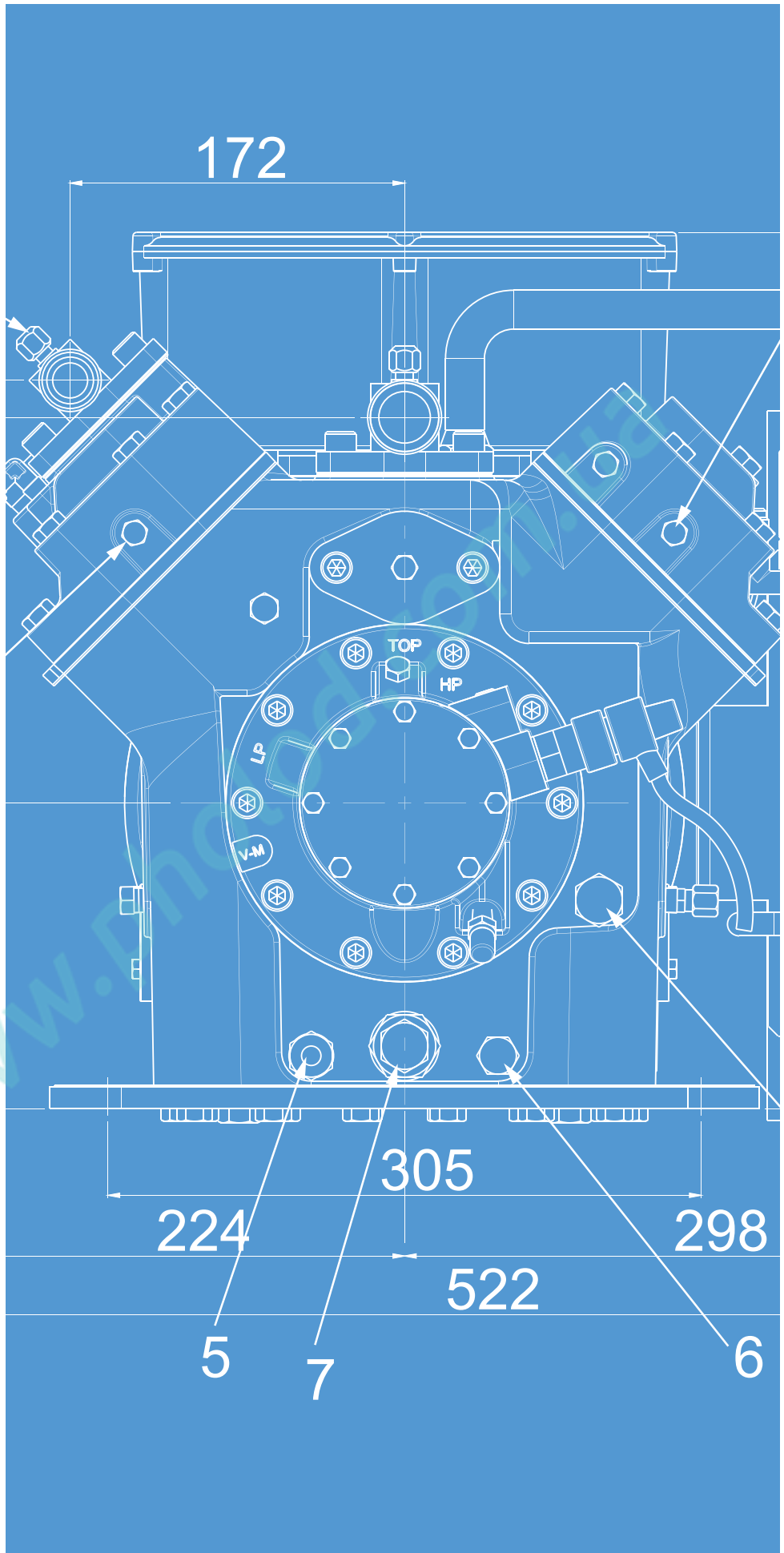

Dimensional drawings

S Series

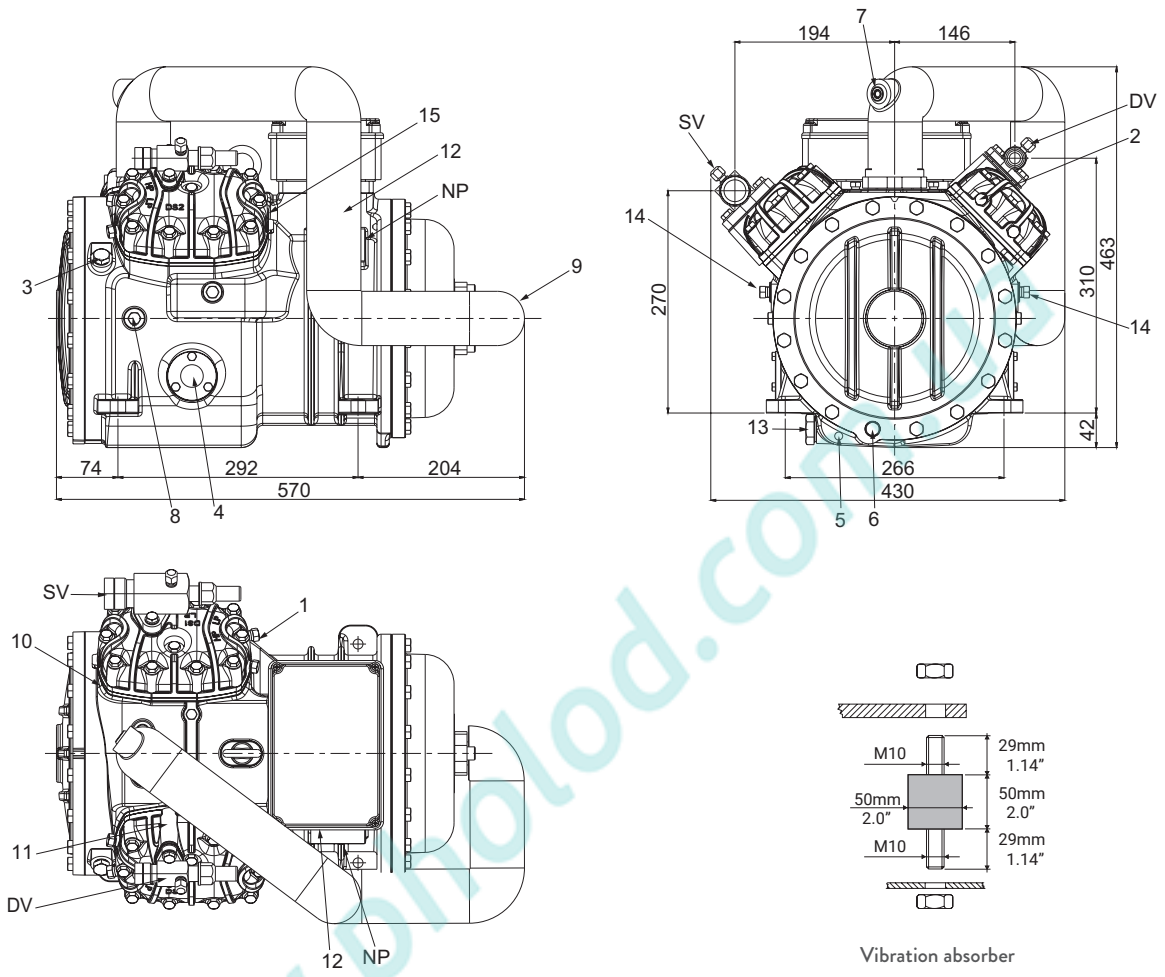

22

1	High pressure plug	1/8" NPT
2	Low pressure plug	1/8" NPT
3	Oil charge plug	1/4" GAS
4	Oil level sight glass	
5	Crankcase heater seat	
6	Oil drain plug	
7	Connection for liquid injection thermostatic valve	
8	Oil return plug	1/4" NPT
9	1st-2nd stage collector	
10	1st stage head	
11	2nd stage head	
12	Intermediate pressure coupling	1/4" NPT
13	Magnetic plug	
14	Coupling for the thermostatic valve equalization line	1/4" NPT
28	Discharge gas temperature sensor	
SV	Suction valve	1 3/8" - 35 mm
DV	Discharge valve	1 7/8" - 22 mm
NP	Nameplate	

2V Series with liquid Sub-cooling

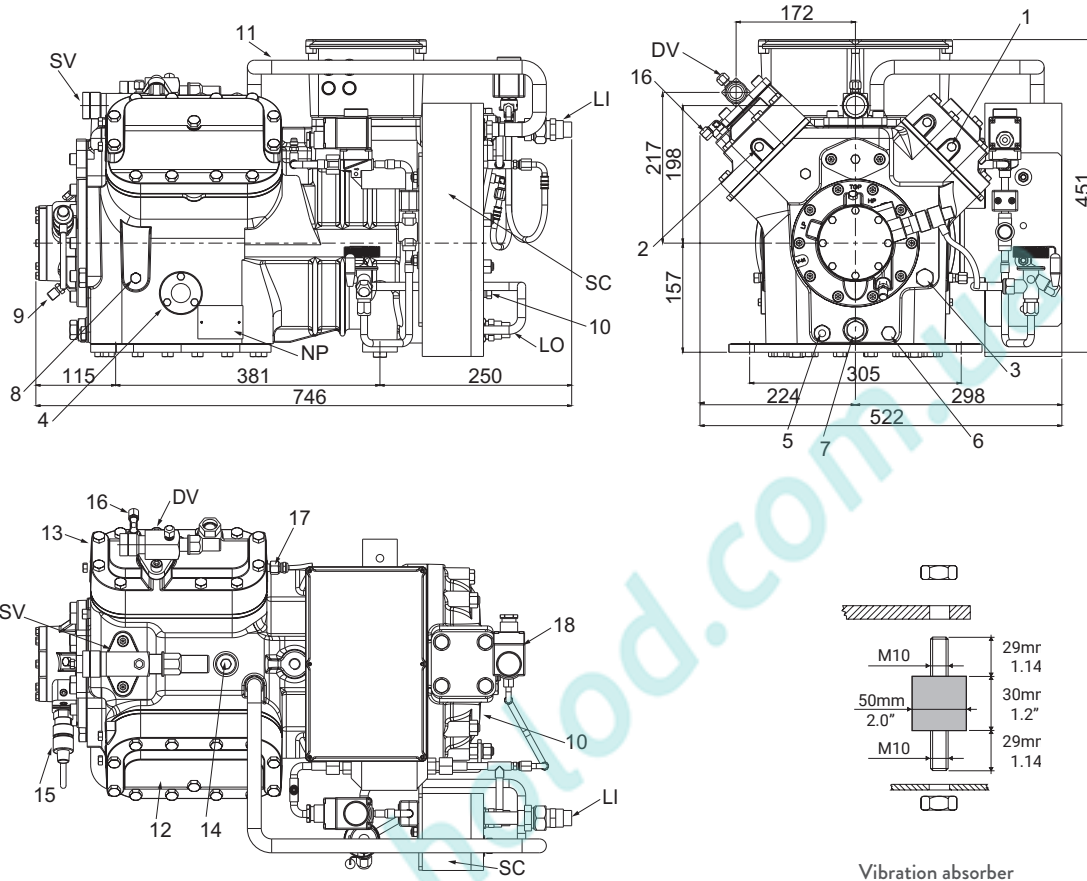

1	High pressure plug	1/8" NPT
2	Low pressure plug	1/8" NPT
3	Oil charge plug	3/8" GAS
4	Oil level sight glass	
5	Crankcase heater seat	
6	Oil drain plug	
7	Oil filter	
8	Oil low pressure plug	1/4" SAE
9	Oil high pressure plug	1/4" SAE
10	Oil return plug	1/4" NPT
11	1st-2nd stage liquid injection collector	
12	1st stage head	
13	2nd stage head	
14	Intermediate pressure coupling	1/4" NPT
15	Oil electronic pressure switch	
16	Coupling for the thermostatic valve equalization line	1/4" SAE
17	Discharge gas temperature sensor	
18	Liquid injection valve	
SV	Suction valve	1 3/8" - 35 mm
DV	Discharge valve	1 1/8" - 29 mm
SC	Liquid sub-cooler	
LI	Sub-cooler liquid inlet	
LO	Sub-cooler liquid outlet	
NP	Nameplate	

2V Series without liquid Sub-cooling

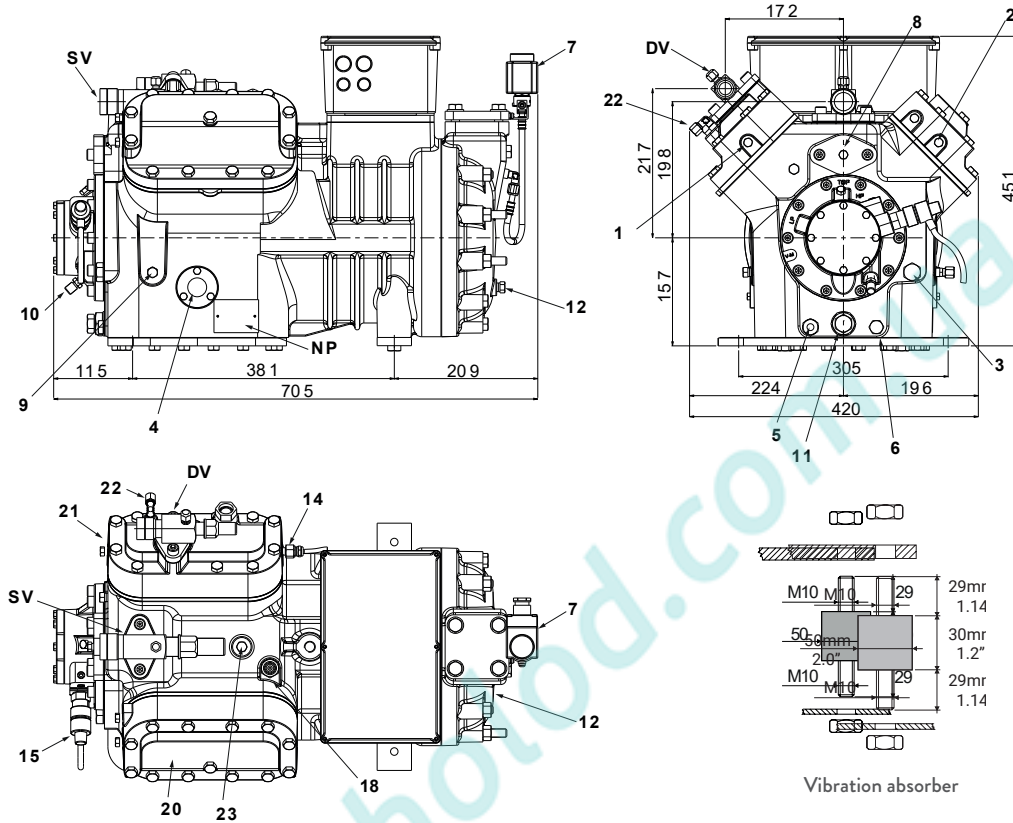

1	High pressure plug	1/8" NPT
2	Low pressure plug	1/8" NPT
3	Oil charge plug	3/8" GAS
4	Oil level sight glass	
5	Crankcase heater seat	
6	Oil drain plug	
7	Oil filter	
8	Oil low pressure plug	1/4" SAE
9	Oil high pressure plug	1/4" SAE
10	Oil return plug	1/4" NPT
11	1st-2nd stage liquid injection collector	3/8" SAE
12	1st stage head	
13	2nd stage head	
14	Intermediate pressure coupling	1/4" NPT
15	Oil electronic pressure switch	
16	Coupling for the thermostatic valve equalization line	1/4" SAE
17	Discharge gas temperature sensor	
18	Liquid injection valve	
SV	Suction valve	1 3/8" - 35 mm
DV	Discharge valve	1 1/8" - 29 mm
SC	Liquid sub-cooler	
LI	Sub-cooler liquid inlet	
LO	Sub-cooler liquid outlet	
NP	Nameplate	

Dimensional drawing

2Z Series with liquid Sub-cooling

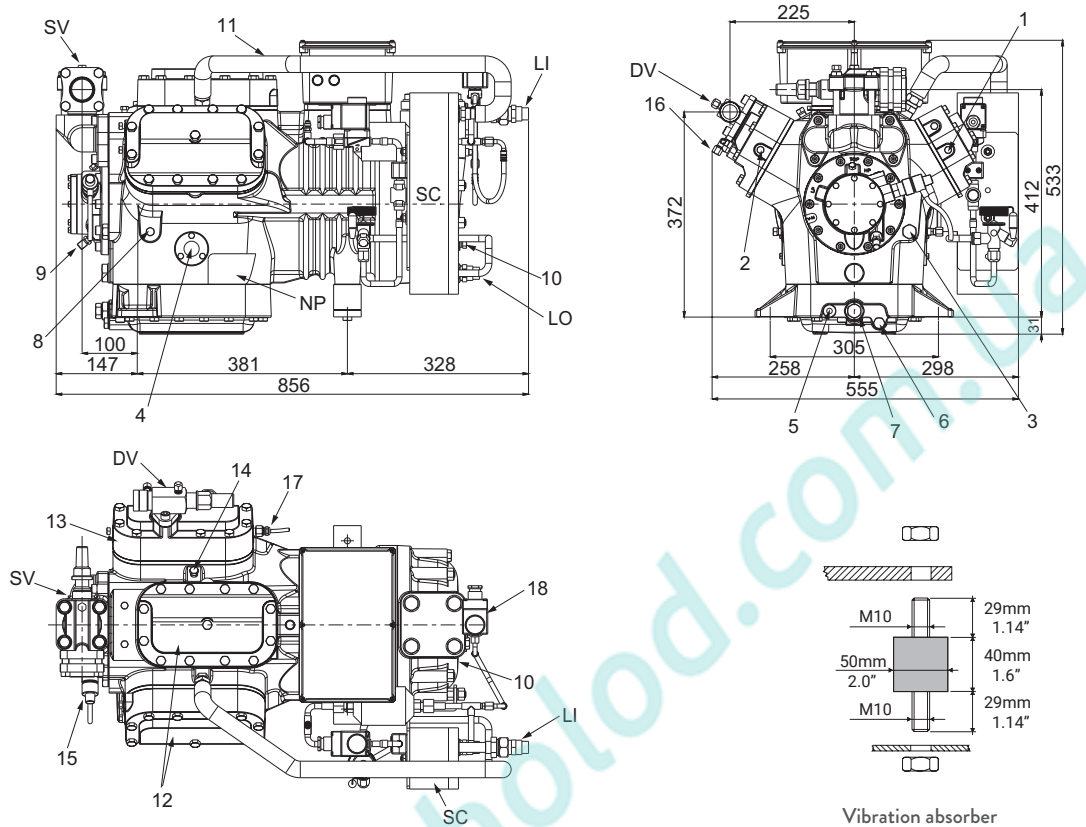

25

1	High pressure plug	1/8" NPT
2	Low pressure plug	1/8" NPT
3	Oil charge plug	3/8" GAS
4	Oil level sight glass	
5	Crankcase heater seat	
6	Oil drain plug	
7	Oil filter	
8	Oil low pressure plug	1/4" SAE
9	Oil high pressure plug	1/4" SAE
10	Oil return plug	1/4" NPT
11	1st-2nd stage liquid injection collector	
12	1st stage head	
13	2nd stage head	
14	Intermediate pressure coupling	1/4" NPT
15	Oil electronic pressure switch	
16	Coupling for the thermostatic valve equalization line	1/4" SAE
17	Discharge gas temperature sensor	
18	Liquid injection valve	
SV	Suction valve 2Z15, 2Z20, 2Z25, 2Z35 & 2Z40 Models	1 5/8" - 42 mm
SV	Suction valve 2Z30, 2Z35 & 2Z40 Models	1 5/8" - 42 mm
DV	Discharge valve 2Z15, 2Z20, 2Z25 Models	1 3/8" - 35 mm
DV	Discharge valve 2Z30 Models	2 1/8" - 54 mm
SC	Liquid sub-cooler	
LI	Sub-cooler liquid inlet	
LO	Sub-cooler liquid outlet	
NP	Nameplate	

2V Series without liquid Sub-cooling

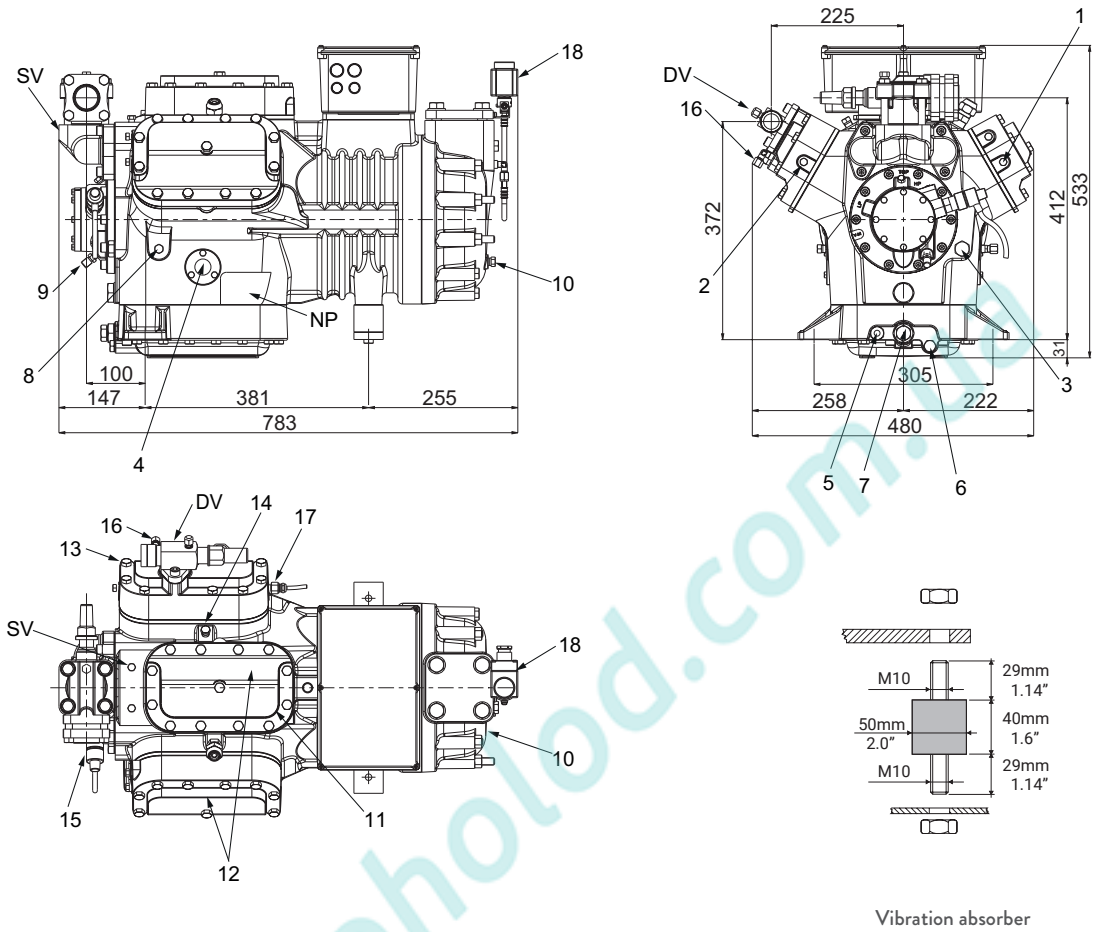

1	High pressure plug	1/8" NPT
2	Low pressure plug	1/8" NPT
3	Oil charge plug	3/8" GAS
4	Oil level sight glass	
5	Crankcase heater seat	
6	Oil drain plug	
7	Oil filter	
8	Oil low pressure plug	1/4" SAE
9	Oil high pressure plug	1/4" SAE
10	Oil return plug	1/4" NPT
11	1st-2nd stage liquid injection collector	5/8" SAE
12	1st stage head	
13	2nd stage head	
14	Intermediate pressure coupling	1/4" NPT
15	Oil electronic pressure switch	
16	Coupling for the thermostatic valve equalization line	1/4" SAE
17	Discharge gas temperature sensor	
18	Liquid injection valve	
SV	Suction valve 2Z15, 2Z20, 2Z25, 2Z35 & 2Z40 Models	1 5/8" - 42 mm
SV	Sution valve 2Z30, 2Z35 & 2Z40 Models	1 5/8" - 42 mm
DV	Discharge valve 2Z15, 2Z20, 2Z25 Models	1 3/8" - 35 mm
DV	Discharge valve 2Z30 Models	2 1/8" - 54 mm
NP	Nameplate	

Cooling system diagram with liquid Sub-cooling

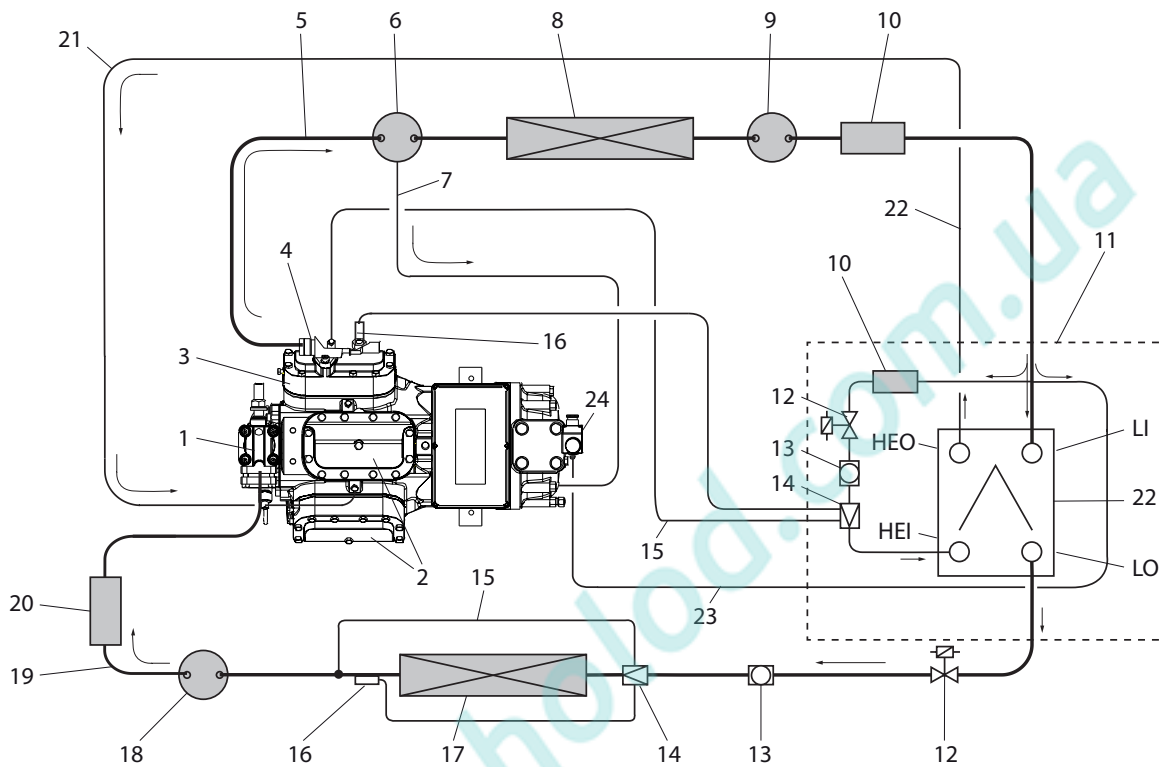

- | | | | |
|----|------------------------------|-----|---|
| 1 | Suction valve | 15 | Thermostatic valve balance line |
| 2 | 1st stage compressor head | 16 | Thermostatic expansion valve bulb |
| 3 | 2nd stage compressor head | 17 | Evaporator |
| 4 | Discharge valve | 18 | Liquid separator |
| 5 | Discharge line | 19 | Suction line |
| 6 | Oil separator | 20 | Suction filter |
| 7 | Compressor oil return line | 21 | Liquid injection line between 1st and 2nd stage |
| 8 | Condenser | 22 | Liquid sub-cooling exchanger |
| 9 | Liquid receiver | 23 | Motor cooling liquid injection line |
| 10 | Dehydrating filter | 24 | Motor cooling liquid injection valve |
| 11 | Liquid sub-cooling kit | LI | Liquid inlet |
| 12 | Solenoid valve | LO | Liquid outlet |
| 13 | Liquid indicator | HEI | Exchanger inlet |
| 14 | Thermostatic expansion valve | HEO | Exchanger outlet |

Cooling system diagram without liquid Sub-cooling

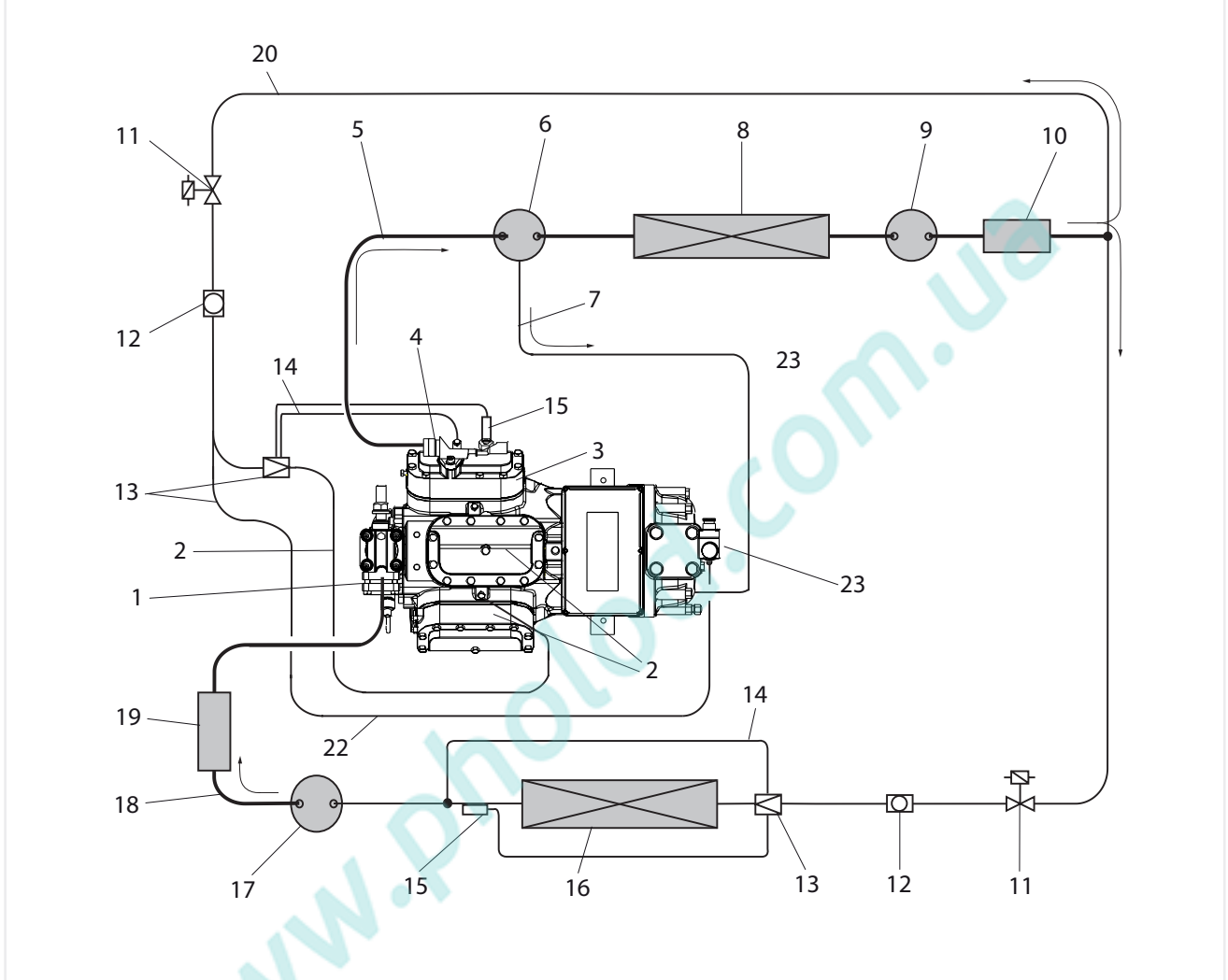

- 1 Suction valve
- 2 1st stage compressor head
- 3 2nd stage compressor head
- 4 Discharge valve
- 5 Discharge line
- 6 Oil separator
- 7 Compressor oil return line
- 8 Condenser
- 9 Liquid receiver
- 10 Dehydrating filter
- 11 Solenoid valve
- 12 Liquid indicator
- 13 Thermostatic expansion valve
- 14 Thermostatic valve balance line
- 15 Thermostatic expansion valve bulb
- 16 Evaporator
- 17 Liquid separator
- 18 Suction line
- 19 Suction filter
- 20 Injection liquid line
- 21 Liquid injection line between 1st and 2nd stage
- 22 Motor cooling liquid injection line
- 23 Motor cooling liquid injection valve

Dimensional drawing

Models	Code	Connections		
		LI Liquid Inlet	LO Liquid Outlet	HEO Exchanger Outlet
		[mm]	[mm]	
R404A - R507 Refrigerants				
S5-26.16Y	T00SK300210	18	18	3/8"
S7-27.19Y	T00SK300220	18	18	3/8"
2V10-42.29Y	T00SK300330	18	18	3/8"
2Z15-60.30Y	T00SK310325	18	18	5/8"
2Z20-72.36Y	T00SK310310	18	18	5/8"
2Z25-84.42Y	T00SK310310	18	18	5/8"
2Z30-102.51Y	T00SK310335	22	18	5/8"
2Z35-112.56Y	T00SK31040	22	18	5/8"
2Z40-123.62Y	T00SK31040	22	18	5/8"

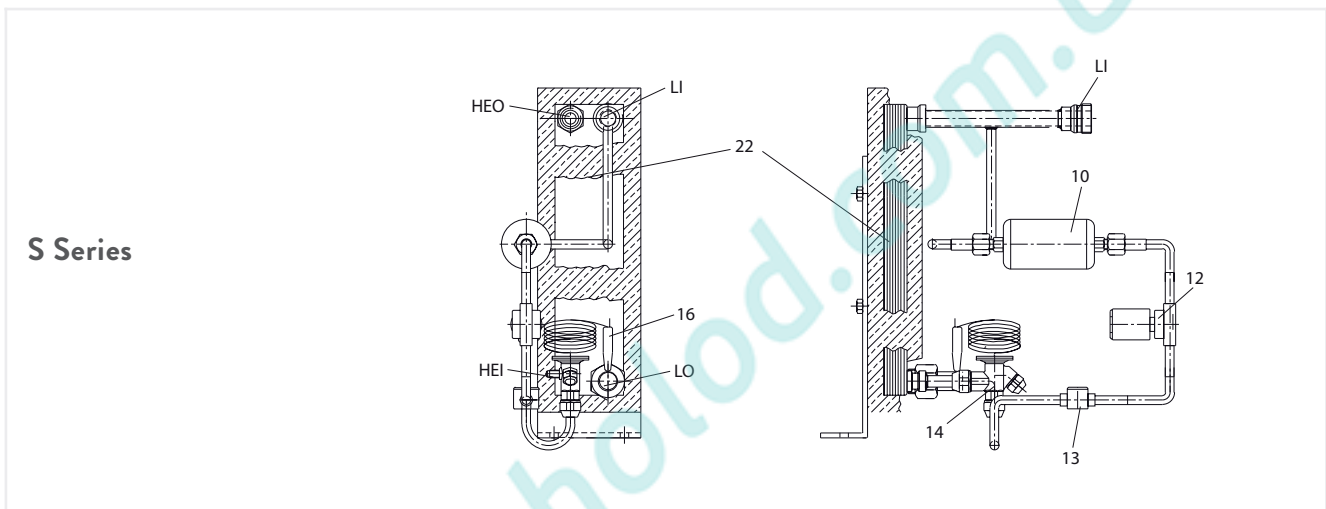

29

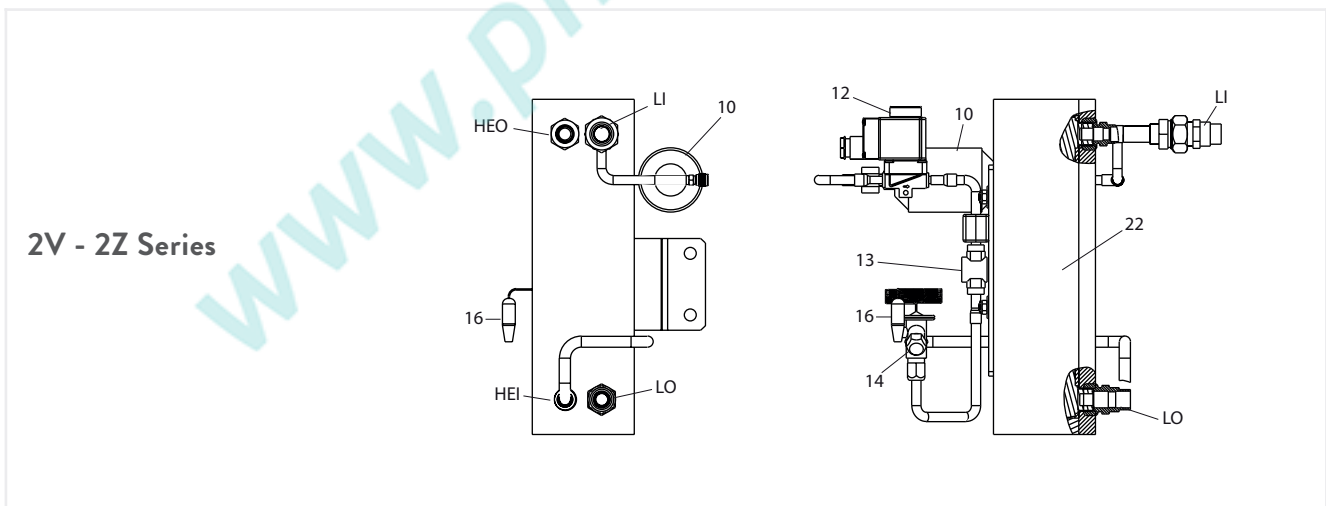

10	Dehydrating filter
12	Solenoid Valve
13	Liquid indicator
14	Thermostatic expansion valve
16	Thermostatic expansion valve bulb
22	Liquid sub-cooling
HEI	Exchanger inlet
HEO	Exchanger outlet
LI	Liquid inlet
LO	Liquid outlet



CONTACT AND SUBSIDIARIES



mail: frascold@frascold.it

web: www.frascold.it

Frascold headquarters

Frascold SpA Via B. Melzi 105
20027 Rescaldina (MI) Italy
Tel. +39 0331 742201 - Fax +39 0331 576102
mail: frascold@frascold.it - web: www.frascold.it

Frascold China

Frascold Refrigeration Co. Ltd
Room 612, 6th Floor,
Jinqiao Life Hub, No.3611
Zhangyang Road, New Pudong
District, Shanghai, CHINA
www.frascold.net
ph. +86 021 58650192
ph. +86 021 58650180
fax +86 021 58650180
frascold.china@frascold.net

Frascold India pvt ltd

C-908, Titanium Square,
Nr. Thaltej Cross Roads, S. G. Road,
Thaltej, Ahmedabad – 380 054
Gujarat, INDIA
Ph. +91 79 29704046/47/48
Fax +91 79 29704049
sales@frascoldindia.com
www.frascoldindia.com

Frascold USA

5901 23rd Drive West, Suite 101
Everett, WA 98203
(855) 547 5600 Office
info@frascoldusa.com
www.frascoldusa.com

Frascold®
BLUE IS BETTER

www.pholod.com.ua



FCAT_105_00_EN